



# Bar Equipment

BOTTLE, KEG & BACK BAR COOLERS



**Continental**<sup>®</sup>  
**Refrigerator**

INNOVATIVE DESIGNS FOR YOUR FOODSERVICE NEEDS

# Bar Equipment

---

## Bottle, Keg, & Back Bar Coolers

Our Bar Equipment is “built to last” with all stainless steel countertops and heavy-duty galvanized interior. Models come standard with a textured baked black enamel finish exterior, providing long-term wear resistance for optimal design and function. *Stainless steel exterior also available.*

## Front-Breathing Air Flow

Intake and exhaust from the front cabinet allows the unit to be flush against the wall or built in.

## Performance & Reliability

Performance-run tested for a minimum of 12 hours providing a highly sophisticated temperature analysis recording, exclusive to each cabinet.





# FLEXIBILITY

## Modifications Made Easy.

At Continental Refrigerator, we know the foodservice industry is an ever-changing environment. We are reminded of this every day through feedback from our customers, both directly and through our network of representatives. In fact, customer feedback has often lead to our custom engineering modifications becoming standard product features.

For this reason, we pride ourselves in delivering feature-rich refrigeration equipment solutions designed specifically for the commercial foodservice market. Whether it's kitchen ambient, food safety, limited space or storage challenges, our products are packed with flexible options that provide **real** operator benefits out of the box. This flexibility, a key differentiator of our products, enables our customers to modify base product features strategic to the way they operate their kitchen or bar environment.

### Shown: KC69N

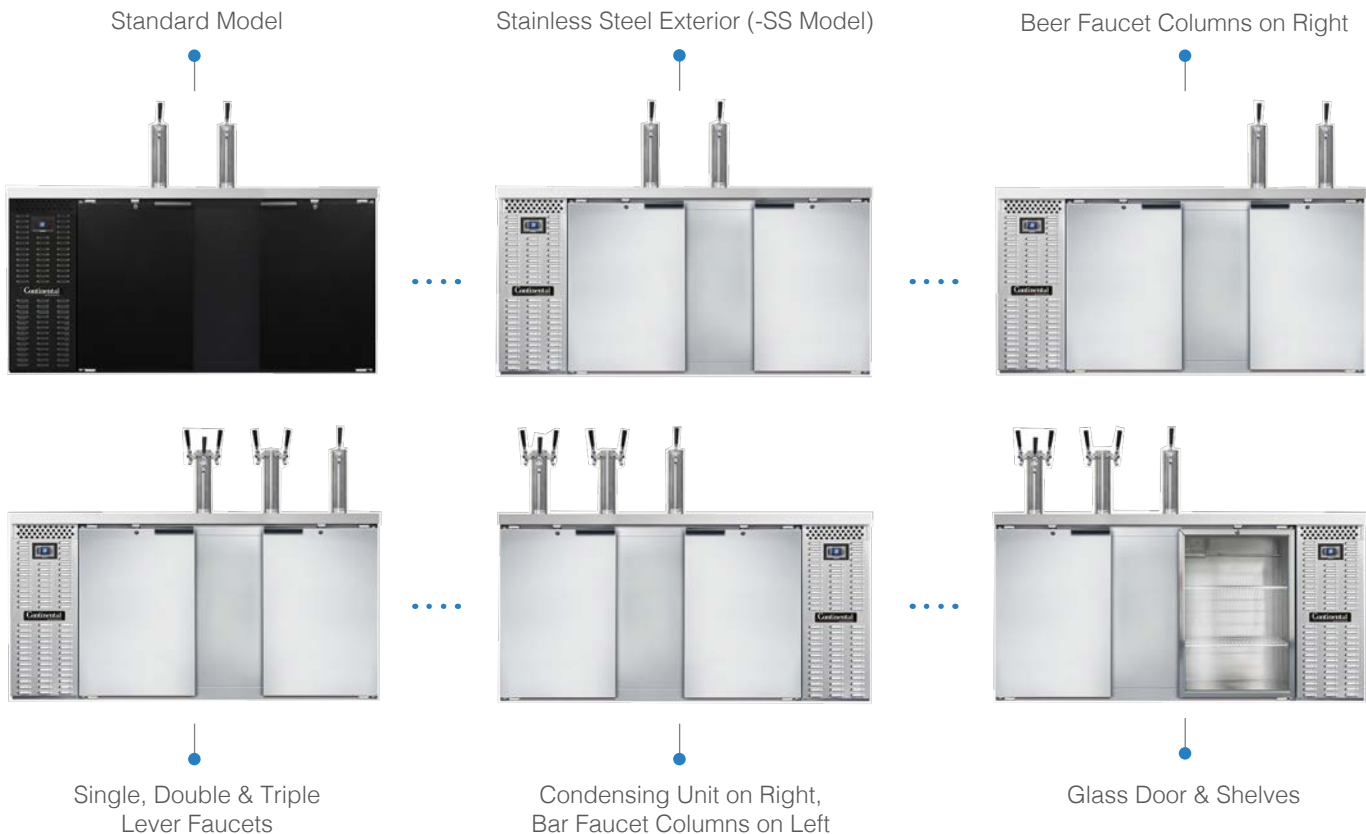

*Consult factory for other modifications*

## Overview of Keg Coolers & Standard Features

### Standard Features

Wear resistant, textured baked black enamel finish exterior (Standard models)

Stainless steel exterior (SS models)

Low profile cabinet design (except 24" models)

Performance-rated front breathing refrigeration system (except 24" models)

### Environmentally-safe R-290 refrigerant

High-density, non-CFC polyurethane foamed-in-place insulation

Stainless steel reinforced threshold

Continuously cooled, 3" diameter beer columns w/ lever faucet, CO<sub>2</sub> pressure relief distributor and CO<sub>2</sub> tubing with clamps

Removable stainless steel drip grate w/ front-mounted drainage hose (pan not removable)

Easily accessible and serviceable slide-out condensing unit (except 24" models)

Electronic controller w/ digital display & hi-low alarm

Readily removable front, rear and side venting louvered grills (except 24" models)

### Automatic, hot gas condensate evaporator

Cylinder-keyed security lock (each door)

Magnetic snap-in door gaskets

Interior light (except 24" models and shallow depth)

5" casters (24" models only) (Cannot be changed)

### Widths

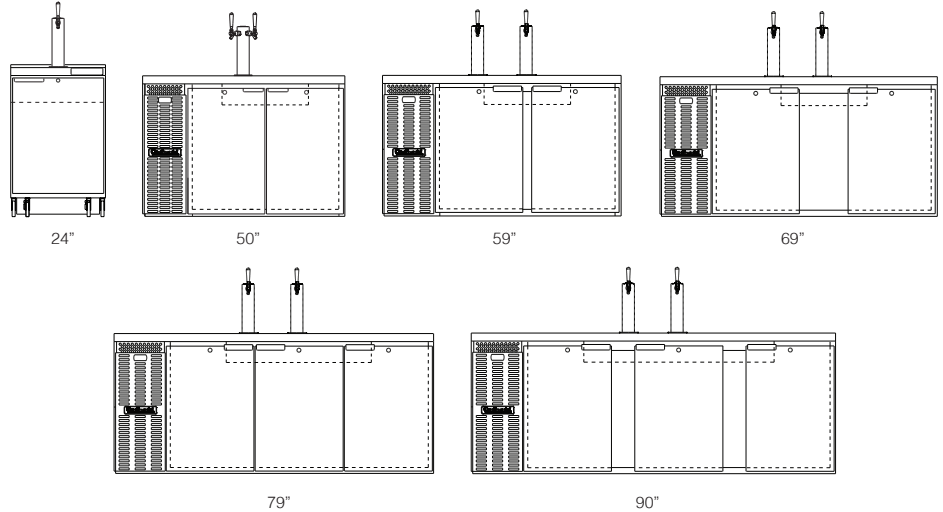

### Side View (Shallow Depth not available on KC24 models)

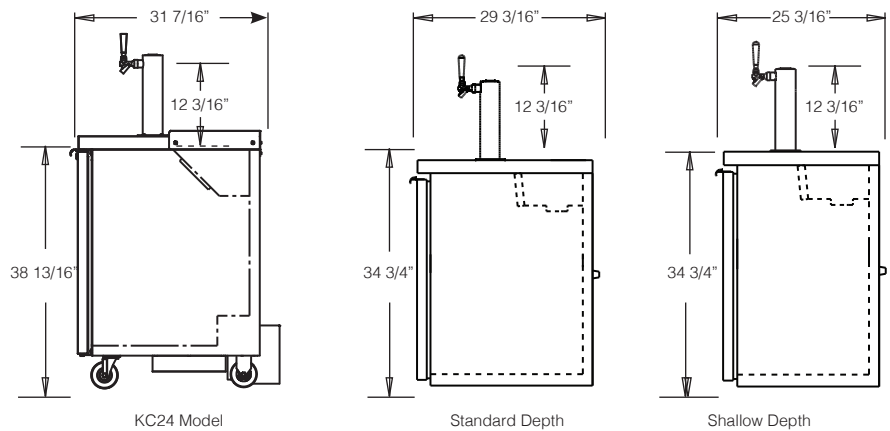

### Keg Capacities (standard depth, 1/2 keg straight wall capacities shown, SW = straight wall, B = barrel)

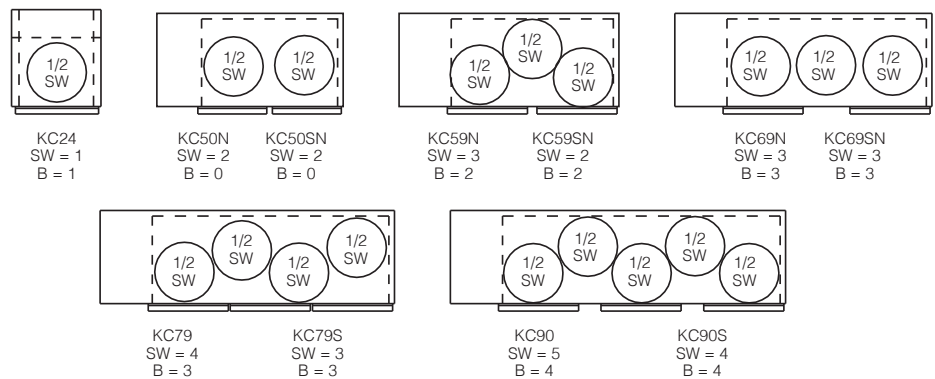



# Overview of Back Bar Coolers & Standard Features

## Widths

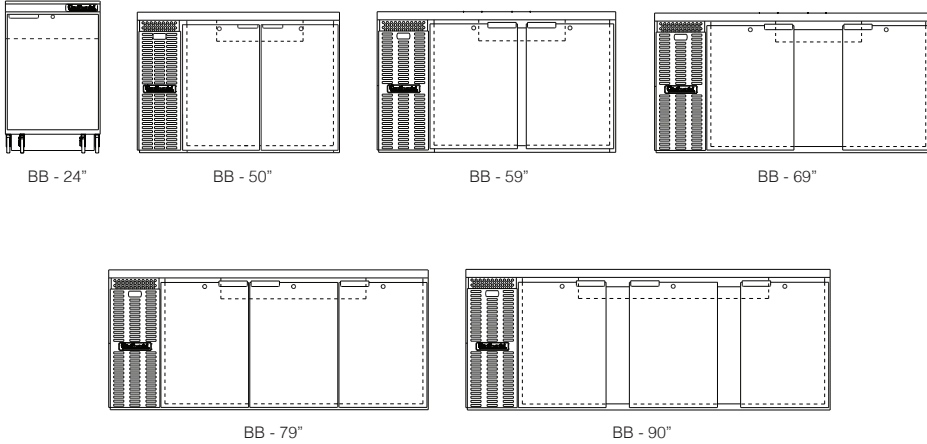

## Depths - Hinged Doors (Shallow Depth or Pass-Thru not available on 24" models)

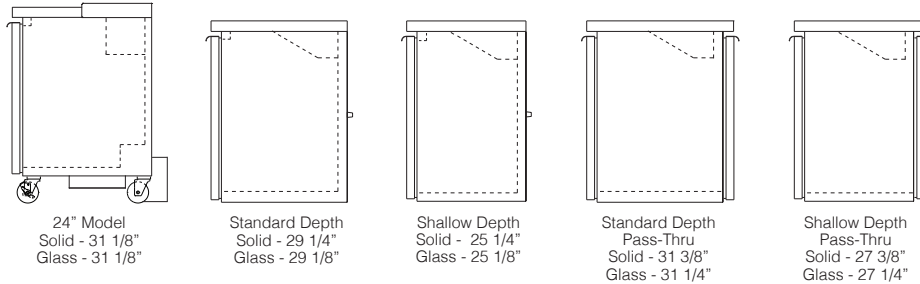

## Depths - Sliding Glass Doors (Sliding Glass Doors not available on 24", 79" or 90" models)

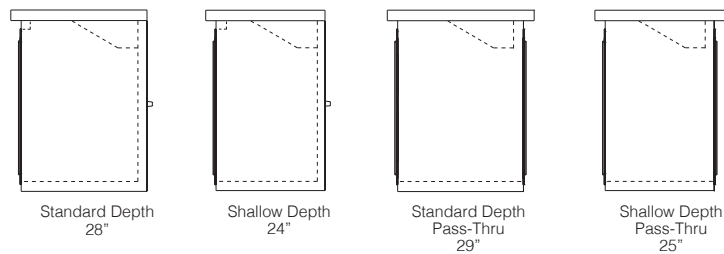

## Door Styles (59" model shown below, all glass is double pane, tempered Low-e)

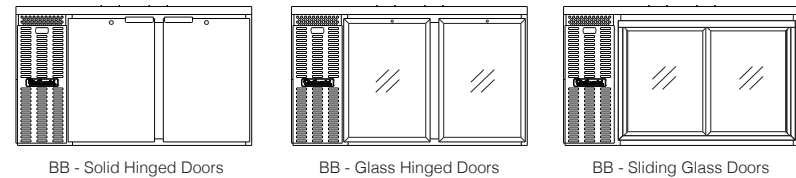

Combination of solid & hinged glass doors available as a Flexible Option

## Standard Features

Wear resistant, textured baked black enamel finish exterior (Standard models)

Stainless steel exterior (SS models)

Low profile cabinet design (except 24" models)

Performance-rated front breathing refrigeration system (except 24" models)

### Environmentally-safe R-290 refrigerant

High-density, non-CFC polyurethane foamed-in-place insulation

Stainless steel reinforced threshold

Extra large, balanced evaporator coil

Heavy-duty, epoxy-coated steel shelves

Easily accessible and serviceable slide-out condensing unit (except 24" models)

Electronic controller w/ digital display & hi-low alarm

Readily removable front, rear, and side venting louvered grills (except 24" models)

### Automatic, hot gas condensate evaporator

Cylinder-keyed security lock (each door)

Magnetic snap-in gasket (each door)

Interior light (except 24" models and shallow depth)

LED interior lighting (Display models)

Spring-loaded, self-closing, double pane, tempered, low-e hinged glass doors (-GD models) (50" - 90" models are not rehingeable)

Self-closing, double pane, tempered, low-e sliding glass doors (-SGD models)

## Overview of Bottle Coolers, Standard Features & Specifications

### Standard Features

Wear resistant, textured baked black enamel finish exterior (Standard models)

Stainless steel exterior (SS Models)

Stainless steel countertop and slide lids, heavy-duty galvanized interior

Performance-rated refrigeration system

**Environmentally-safe R-290 refrigerant** (except Deep Chill models)

High density, non-CFC polyurethane foamed-in-place insulation

Full length, extra large coil

Easily accessible and serviceable slide-out condensing unit (Cannot be switched to right)

Electronic controller w/ digital display & hi-low alarm

**Expansion valve system** (50", 64", 95" models only)

Front, rear, and side venting louvers (except 24" models)

Heavy-duty, epoxy-coated, adj. steel wire storage bin dividers

Heavy-duty cap opener w/ extra capacity

Removable cap catcher

**Automatic, hot gas condensate evaporator** (Deep Chill models: automatic time defrosting period is timer initiated and temperature terminated)

Easily accessible, front-mounted cleanout drainage hose

### Widths & Depth

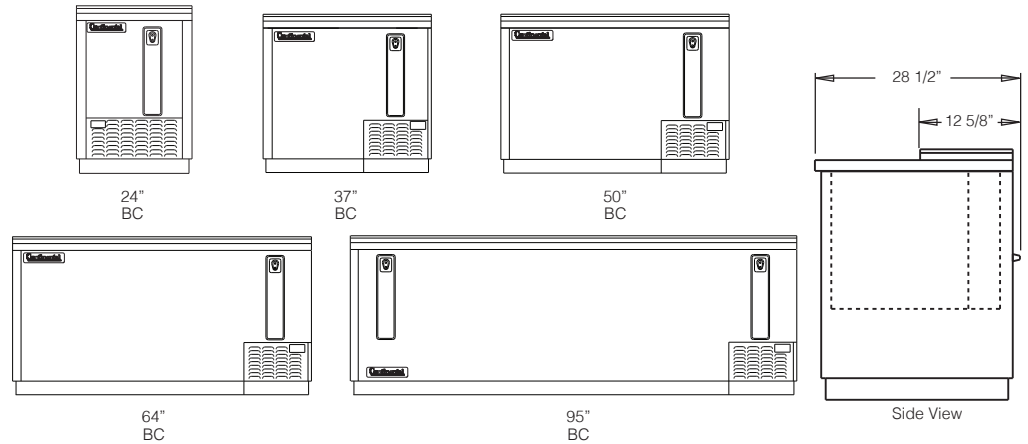

### Bottle Coolers Product Capacity

MODEL	12 OZ. BOTTLES (CASES)	12 OZ. CANS (CASES)
BC24N	4 1/2	7 1/2
BC37N	12	18 1/2
BC50N	18	27
BC64N	25	37
BC95	40	59

### Temperatures

MODEL	Temperature
BC-N Standard	38°F - 41°F
CBC-DC Deep Chill	32°F

### Specifications

#### Bottle Coolers

SIZE	STD BLACK ENAMEL EXTERIOR	STAINLESS STEEL EXTERIOR	EXTERIOR DIMENSIONS INCHES W x D x H	CAPACITY BTU/HR*	H.P.	SHIP WEIGHT**
24"	BC24N	BC24NSS	24 x 29 1/8 x 34 3/4	1800	1/5	205
37"	BC37N	BC37NSS	37 x 29 1/8 x 33 1/2	1800	1/5	215
50"	BC50N	BC50NSS	50 x 29 1/8 x 33 1/2	1910	1/3	265
64"	BC64N	BC64NSS	64 x 29 1/8 x 33 1/2	2050	1/3	376
95"	BC95N	BC95NSS	95 x 29 1/8 x 33 1/2	3100	1/2	435

#### Deep Chill Bottle Coolers

24"	CBC24-DC	CBC24-SS-DC	24 x 29 1/8 x 34 3/4	1800	1/5	205
37"	CBC37-DC	CBC37-SS-DC	37 x 29 1/8 x 33 1/2	1800	1/5	215
50"	CBC50-DC	CBC50-SS-DC	50 x 29 1/8 x 33 1/2	1910	1/3	265
64"	CBC64-DC	CBC64-SS-DC	64 x 29 1/8 x 33 1/2	2050	1/3	376
95"	CBC95-DC	CBC95-SS-DC	95 x 29 1/8 x 33 1/2	3100	1/2	435

\*BTU/HR Rating @ +25°F, 90°F ambient. 10 ft. cord and plug attached (115-60-1 volts)

\*\*Ship weight for Suffix "SS" models is on average 5% higher than Standard models. Refer to Specification Sheet for shipping weight of these models.

## Specifications - Keg & Back Bar Coolers

SIZE	STANDARD BLACK ENAMEL EXTERIOR	STAINLESS STEEL EXTERIOR	EXTERIOR DIMENSIONS INCHES W x D x H	CAPACITY BTU/HR*	H.P.	SHIP WEIGHT**
<b>Keg Coolers, Standard Depth</b>						
24"	KC24N	KC24NSS	24 1/8 x 31 7/16 x 38 13/16	1620	1/5	210
50"	KC50N	KC50NSS	50 x 29 3/16 x 34 3/4	1800	1/4	355
59"	KC59N	KC59NSS	59 x 29 3/16 x 34 3/4	2025	1/4	385
69"	KC69N	KC69NSS	69 x 29 3/16 x 34 3/4	2250	1/4	415
79"	KC79N	KC79NSS	79 x 29 3/16 x 34 3/4	2500	1/3	455
90"	KC90N	KC90NSS	90 x 29 3/16 x 34 3/4	2670	1/2	505

### Keg Coolers, Shallow Depth

50"	KC50SN	KC50SNSS	50 x 25 3/16 x 34 3/4	1800	1/4	355
59"	KC59SN	KC59SNSS	59 x 25 3/16 x 34 3/4	2025	1/4	385
69"	KC69SN	KC69SNSS	69 x 25 3/16 x 34 3/4	2250	1/4	415
79"	KC79SN	KC79SNSS	79 x 25 3/16 x 34 3/4	2500	1/3	455
90"	KC90SN	KC90SNSS	90 x 25 3/16 x 34 3/4	2670	1/2	505

\*BTU/HR Rating @ +25°F, 90°F ambient. 10 ft. cord and plug attached

### Back Bar Coolers, Standard Depth

24"	BB24N	BB24NSS	24 1/8 x 31 7/16 x 38 13/16	1620	1/5	210
50"	BB50N	BB50NSS	50 x 29 3/16 x 34 3/4	1800	1/4	355
59"	BB59N	BB59NSS	59 x 29 3/16 x 34 3/4	2025	1/4	385
69"	BB69N	BB69NSS	69 x 29 3/16 x 34 3/4	2250	1/4	415
79"	BB79N	BB79NSS	79 x 29 3/16 x 34 3/4	2500	1/3	455
90"	BB90N	BB90NSS	90 x 29 3/16 x 34 3/4	2670	1/2	505

### Back Bar Coolers, Shallow Depth

50"	BB50SN	BB50SNSS	50 x 25 3/16 x 34 3/4	1800	1/4	355
59"	BB59SN	BB59SNSS	59 x 25 3/16 x 34 3/4	2025	1/4	385
69"	BB69SN	BB69SNSS	69 x 25 3/16 x 34 3/4	2250	1/4	415
79"	BB79SN	BB79SNSS	79 x 25 3/16 x 34 3/4	2500	1/3	455
90"	BB90SN	BB90SNSS	90 x 25 3/16 x 34 3/4	2670	1/3	505

### Back Bar Coolers, Pass-Thru Standard Depth

50"	BB50NPT	BB50NSSPT	50 x 31 3/8 x 34 3/4	1800	1/4	355
59"	BB59NPT	BB59NSSPT	59 x 31 3/8 x 34 3/4	2025	1/4	385
69"	BB69NPT	BB69NSSPT	69 x 31 3/8 x 34 3/4	2250	1/4	415
79"	BB79NPT	BB79NSSPT	79 x 31 3/8 x 34 3/4	2500	1/3	455
90"	BB90NPT	BB90NSSPT	90 x 31 3/8 x 34 3/4	2670	1/3	505

### Back Bar Coolers, Pass-Thru Shallow Depth

50"	BB50SNPT	BB50SNSSPT	50 x 27 3/8 x 34 3/4	1800	1/4	355
59"	BB59SNPT	BB59SNSSPT	59 x 27 3/8 x 34 3/4	2025	1/4	385
69"	BB69SNPT	BB69SNSSPT	69 x 27 3/8 x 34 3/4	2250	1/4	415
79"	BB79SNPT	BB79SNSSPT	79 x 27 3/8 x 34 3/4	2500	1/3	455
90"	BB90SNPT	BB90SNSSPT	90 x 27 3/8 x 34 3/4	2670	1/3	505

\*BTU/HR Rating @ +25°F, 90°F ambient.  
10 ft. cord and plug attached (115-60-1 volts)

\*\*Ship weight for Suffix "SS" models is on average 5% higher than Standard models. Refer to Specification Sheet for shipping weight of these models.



## Specifications - Back Bar Display Coolers & Cocktail Refrigerator

SIZE	STANDARD BLACK ENAMEL EXTERIOR	STAINLESS STEEL EXTERIOR	EXTERIOR DIMENSIONS INCHES W x D x H	CAPACITY BTU/HR*	H.P.	SHIP WEIGHT**
<b>Back Bar Display Coolers w/ Hinged Glass Doors, Standard Depth</b>						
24"	BB24NGD	BB24NSSGD	24 1/8 x 30 7/8 x 38 13/16	1620	1/5	220
50"	BB50NGD	BB50NSSGD	50 x 28 5/8 x 34 3/4	1800	1/4	365
59"	BB59NGD	BB59NSSGD	59 x 28 5/8 x 34 3/4	2025	1/4	395
69"	BB69NGD	BB69NSSGD	69 x 28 5/8 x 34 3/4	2250	1/4	425
79"	BB79NGD	BB79NSSGD	79 x 28 5/8 x 34 3/4	2500	1/3	465
90"	BB90NGD	BB90NSSGD	90 x 28 5/8 x 34 3/4	2670	1/3	515
<b>Back Bar Display Coolers w/ Hinged Glass Doors, Shallow Depth</b>						
50"	BB50NSGD	BB50NSSGD	50 x 24 5/8 x 34 3/4	1800	1/4	365
59"	BB59NSGD	BB59NSSGD	59 x 24 5/8 x 34 3/4	2025	1/4	395
69"	BB69NSGD	BB69NSSGD	69 x 24 5/8 x 34 3/4	2250	1/4	425
79"	BB79NSGD	BB79NSSGD	79 x 24 5/8 x 34 3/4	2500	1/3	465
90"	BB90NSGD	BB90NSSGD	90 x 24 5/8 x 34 3/4	2670	1/3	515
<b>Back Bar Display Coolers w/ Hinged Glass Doors, Pass-Thru Standard Depth</b>						
50"	BB50NGDPT	BB50NSSGDPT	50 x 30 1/4 x 34 3/4	1800	1/4	365
59"	BB59NGDPT	BB59NSSGDPT	59 x 30 1/4 x 34 3/4	2025	1/4	395
69"	BB69NGDPT	BB69NSSGDPT	69 x 30 1/4 x 34 3/4	2250	1/4	425
79"	BB79NGDPT	BB79NSSGDPT	79 x 30 1/4 x 34 3/4	2500	1/3	465
90"	BB90NGDPT	BB90NSSGDPT	90 x 30 1/4 x 34 3/4	2670	1/3	515
<b>Back Bar Display Coolers w/ Hinged Glass Doors, Pass-Thru Shallow Depth</b>						
50"	BB50NSGDPT	BB50NSSGDPT	50 x 26 1/4 x 34 3/4	1800	1/4	365
59"	BB59NSGDPT	BB59NSSGDPT	59 x 26 1/4 x 34 3/4	2025	1/4	395
69"	BB69NSGDPT	BB69NSSGDPT	69 x 26 1/4 x 34 3/4	2250	1/4	425
79"	BB79NSGDPT	BB79NSSGDPT	79 x 26 1/4 x 34 3/4	2500	1/3	465
90"	BB90NSGDPT	BB90NSSGDPT	90 x 26 1/4 x 34 3/4	2670	1/3	515
<b>Back Bar Display Coolers w/ Sliding Glass Doors, Standard Depth</b>						
50"	BB50NSGD	BB50NSSGD	50 x 28 x 34 3/4	1800	1/4	365
59"	BB59NSGD	BB59NSSGD	59 x 28 x 34 3/4	2025	1/4	395
69"	BB69NSGD	BB69NSSGD	69 x 28 x 34 3/4	2250	1/4	425
<b>Back Bar Display Coolers w/ Sliding Glass Doors, Shallow Depth</b>						
50"	BB50SNSGD	BB50NSSSGD	50 x 24 x 34 3/4	1800	1/4	365
59"	BB59SNSGD	BB59NSSSGD	59 x 24 x 34 3/4	2025	1/4	395
69"	BB69SNSGD	BB69NSSSGD	69 x 24 x 34 3/4	2250	1/4	425
<b>Back Bar Display Coolers w/ Sliding Glass Doors, Pass-Thru Standard Depth</b>						
50"	BB50NSGDPT	BB50NSSGDPT	50 x 29 x 34 3/4	1800	1/4	365
59"	BB59NSGDPT	BB59NSSGDPT	59 x 29 x 34 3/4	2025	1/4	395
69"	BB69NSGDPT	BB69NSSGDPT	69 x 29 x 34 3/4	2250	1/4	425
<b>Back Bar Display Coolers w/ Sliding Glass Doors, Pass-Thru Shallow Depth</b>						
50"	BB50SNSGDPT	BB50NSSSGDPT	50 x 25 x 34 3/4	1800	1/4	365
59"	BB59SNSGDPT	BB59NSSSGDPT	59 x 25 x 34 3/4	2025	1/4	395
69"	BB69SNSGDPT	BB69NSSSGDPT	69 x 25 x 34 3/4	2250	1/4	425

\*BTU/HR Rating @ +25°F, 90°F ambient. 10 ft. cord and plug attached

\*\*Ship weight for Suffix "SS" models is on average 5% higher than Standard models. Refer to Specification Sheet for shipping weight of these models.

### Keg Coolers

- Epoxy-coated shelves with clips
- Stainless steel shelves with clips
- Wine racks
- Stainless steel interior
- Single, dual & triple angle faucet
- Faucet lock
- Casters or legs
- Condensing unit on left or right (except 24" models)
- Tower placement (consult factory)
- Riser base (field installed, 50" - 90" models only)

### Bottle Coolers

- Lid locks
- Add'l wire bin dividers
- Stainless steel interior
- Expansion valve system
- Casters or legs
- Automatic electric condensate evaporator (37" - 95" models only)



Faucet lock

### Back Bar Coolers

- Add'l epoxy-coated shelves with clips
- Stainless steel shelves with clips
- Wine racks
- Food storage rated stainless steel interior (NSF-7) (except -SGD models)
- Casters or legs
- Condensing unit left or right (except 24" models)
- Riser base (field installed)
- Sliding glass door lock (-SGD models)



Wine rack



Lid lock for CBC models

## Engineering, Manufacturing & Quality Control

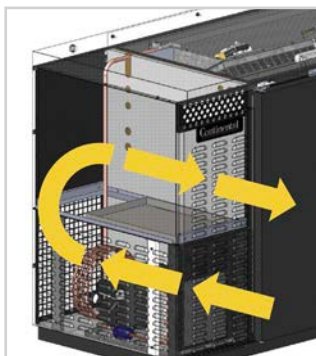

View of front breathing air flow on BB/KC models

Continental Refrigerator engineers and builds our Bar Equipment to meet the most stringent specifications demanded by consultants and service operators. All cabinets are constructed of top quality materials and components, attributing to their genuine ruggedness and durability. Bar Equipment is designed with enhancements to endure everyday use in harsh bar operating environments.

Prior to factory shipping, all models are performance-run tested for a minimum of 12 hours, providing a highly sophisticated temperature analysis recording, exclusive to each individual cabinet. This recording is then supplied, along with the unit's operation manual, for the customer. A final leak test, vibration check, noise level and visual examination is made by our quality control team, to assure a superior product is shipped from our factory.

### Air Flow

Intake air is drawn through the louvers at the bottom half of the front grill, and then through the condenser coil. In cases where the rear of the unit is blocked, the air is forced to discharge through the holes at the top half of the front grill.

*Product design and specifications are subject to change without prior notice.*

## How to Buy

LOCAL SALES REPRESENTATIVES			STATES COVERED
Wyllie Marketing	Weymouth, MA	(781) 340-6157	<b>ME, RI, NH, MA, VT, CT</b>
Link 2 Hospitality Solutions	Rochester, NY	(585) 254-1780	<b>Upstate NY</b>
Pecinka Ferri Associates	Fairfield, NJ	(973) 812-4277	<b>N. NJ, New York City</b>
Schmid Dewland & Associates	Marlton, NJ	(856) 783-3400	<b>E. PA, DE, S. &amp; Central NJ</b>
Link 2 Hospitality Solutions	Bridgeville, PA	(412) 341-2020	<b>W. PA, W. VA (except Panhandle)</b>
High Sabatino Associates, Inc.	Jessup, MD	(301) 470-7051	<b>DC, MD, VA, W. VA (Panhandle)</b>
Stiefel Associates, Inc.	Lansing, MI	(517) 393-3019	<b>MI (except Upper Peninsula)</b>
Dick Stanley & Associates	Pickerington, OH	(800) 833-0797	<b>OH, KY</b>
Gabriel Group	Fishers, IN	(800) 832-6442	<b>IN</b>
Jay Mark Group, LTD	Elk Grove Village, IL	(847) 545-1918	<b>N. IL</b>
North Star Agency	Plymouth, MN	(763) 545-1400	<b>MN, ND, SD</b>
Mirkovich & Associates	Waukesha, WI	(630) 792-0080	<b>WI, MI (Upper Peninsula)</b>
Select Marketing	St. Louis, MO	(314) 961-3332	<b>MO, KS, IA, NE, S. IL</b>
Master Marketing Carolina	High Shoals, NC	(704) 860-0092	<b>NC, SC</b>
Pro-Quip Foodservice	Little Rock, AR	(501) 221-7120	<b>AR, LA, MS, W. TN (W. of Tenn. River)</b>
The Veitch Group	Ft. Lauderdale, FL	(954) 316-6162	<b>FL (except Panhandle)</b>
Merkolat	Davie, FL	(561) 594-7153	<b>Latin America, Caribbean</b>
Carman-Girard Associates	Atlanta, GA	(770) 457-6548	<b>AL, FL (Panhandle), GA, E. TN (E. of Tenn River)</b>
Ignite Foodservice Solutions	Denver, CO	(303) 433-0124	<b>CO, S. ID, MT, UT WY</b>
Roller & Associates	Seattle, WA	(206) 547-3555	<b>WA, OR, AK, N. ID</b>
Foodservice Equipment Agents	Anaheim, CA	(714) 693-3329	<b>AZ (Bull Head City), S. CA, S. NV</b>
Inform Marketing Group	Walnut Creek, CA	(510) 337-0420	<b>N. CA, N. NV</b>
Ignite Foodservice Solutions	Phoenix, AZ	(303) 433-0124	<b>AZ (except Bull Head City), NM, TX (El Paso)</b>
Forbes Hever & Wallace, Inc.	Coppell, TX	(972) 219-8898	<b>OK, TX (except El Paso)</b>



A Division of National Refrigeration & Air Conditioning Products

Continental Refrigerator | Local: (215) 244-1400  
539 Dunksferry Road | Toll Free: (800) 523-7138  
Bensalem, PA 19020 | Fax: (215) 244-9579

[www.continentalrefrigerator.com](http://www.continentalrefrigerator.com)

# Continental<sup>®</sup>

Refrigerator

INNOVATIVE DESIGNS FOR YOUR FOODSERVICE NEEDS



PROUDLY  
DESIGNED & ASSEMBLED  
IN THE U.S.A.