

## INSTALLATION AND OPERATIONS MANUAL

INCLUDES  
**R290**  
MODELS



## Milk Coolers

Forced Air & Cold Wall

Please fill in the following information for your NEW unit, carefully read the instructions in this manual and file it for future reference.

MODEL NO. \_\_\_\_\_

SERIAL NO. \_\_\_\_\_

PURCHASED FROM \_\_\_\_\_

INSTALL DATE \_\_\_\_\_

SCAN this code  
to download manual



**1-800-523-7138**

**Continental Refrigerator**  
*A Division of National Refrigeration  
& Air Conditioning Products, Inc.*  
539 Dunksferry Road  
Bensalem, PA 19020-5908  
P 215-244-1400  
F 215-244-9579  
[www.continentalrefrigerator.com](http://www.continentalrefrigerator.com)



# Continental<sup>®</sup>

Refrigerator

**Some models utilize R-290 refrigerant, which is flammable.**  
**Refer to data tag to see what refrigerant is used on your product of choice.**

REFER HERE FOR  
REFRIGERANT  
TYPE. IF R-290,  
SEE BELOW.

Continental Refrigerator					
539 Dunkasferry Road • Bensalem, PA 19020-5908					
215-244-1400 • 800-523-7138 • FAX: 215-244-9579					
Division of National Refrigeration and Air Conditioning Products, Inc.					
MODEL	SERIAL				
POWER SUPPLY	WIRES	VOLTS		HZ.	PH.
	VOLTS	HERTZ	PHASE	AMPS.	
CABINET					
COND. UNIT					
DEFROST					
REFRIGERANT TYPE	AMOUNT OZS.				
DESIGN PRESSURE LIMIT	PSI LOW SIDE		PSI HIGH SIDE		
COMMERCIAL REFRIGERATOR FREEZER					
ETL LISTED 53533			NSF		
CONFORMS TO U.L. STANDARD 471					
IMPORTANT NOTICE: FOR WARRANTY PARTS AND SERVICE AUTHORIZATION CALL THE SERVICE DEPARTMENT AT 1-800-523-7138					

**WARNING:** Do not damage the refrigerant circuit. Do not store explosive substances, such as aerosol cans with flammable propellant, in this appliance. Component parts shall be replaced with like components and servicing shall be done by authorized service personnel to reduce the risk of possible ignition.

### **FOR FLAMMABLE (R-290) REFRIGERANT ONLY:**

**DANGER:** RISK OF FIRE OR EXPLOSION. FLAMMABLE REFRIGERANT USED. DO NOT USE MECHANICAL DEVICES TO DEFROST REFRIGERATOR. DO NOT PUNCTURE REFRIGERANT TUBING.

**DANGER:** RISK OF FIRE OR EXPLOSION. FLAMMABLE REFRIGERANT USED. TO BE REPAIRED ONLY BY TRAINED SERVICE PERSONNEL. DO NOT PUNCTURE REFRIGERANT TUBING.

**CAUTION:** RISK OF FIRE OR EXPLOSION. FLAMMABLE REFRIGERANT USED. CONSULT REPAIR MANUAL, OWNERS GUIDE BEFORE ATTEMPTING TO SERVICE THIS PRODUCT. ALL SAFETY PRECAUTIONS MUST BE FOLLOWED.

**CAUTION:** RISK OF FIRE OR EXPLOSION. DISPOSE OF PROPERLY IN ACCORDANCE WITH FEDERAL OR LOCAL REGULATIONS. FLAMMABLE REFRIGERANT USED.

**CAUTION:** RISK OF FIRE OR EXPLOSION DUE TO PUNCTURE OF REFRIGERANT TUBING; FOLLOW HANDLING INSTRUCTIONS CAREFULLY. FLAMMABLE REFRIGERANT USED.

# TABLE OF CONTENTS

	Page
<b>Receiving Your New Model</b> .....	<b>3</b>
<b>General Information and Important Operating Facts</b> .....	<b>3</b>
<b>Uncrating Your New Model</b> .....	<b>3</b>
<b>Installation and Location</b> .....	<b>4</b>
Ventilation .....	4
Floor Drains and Loads .....	4
Cabinet Clean Out Drain and Hose .....	4
Condensate Pan .....	5
Door Latch and Lid Lock .....	6
Latch Adjustment and Lock Replacement .....	6
Removal of Top Assembly .....	7
<b>Interior Accessories</b> .....	<b>7</b>
<b>Initial Cleaning Procedure</b> .....	<b>7</b>
<b>Start-Up Procedure</b> .....	<b>7</b>
Electrical Connections .....	7
Start-Up Checklist .....	8
<b>Operation</b> .....	<b>8</b>
Refrigeration System and Adjustment (Cold Wall) .....	8
Refrigeration System and Adjustment (Forced Air) .....	8
Electronic Control Display and Buttons .....	9
Initial Sequence of Operation .....	9
How to Calibrate the Electronic Control .....	9
How to Change the Set-Point .....	10
Anti-Condensate Control .....	10
How to Initiate a Manual Defrost .....	10
How to Change the Defrost Interval .....	10
Electronic Control Error Codes .....	11
<b>Maintenance</b> .....	<b>11</b>
Periodic Cleaning Procedure .....	11
General Preventative Maintenance .....	12
Care and Cleaning of Stainless Steel .....	12
<b>Parts and Service</b> .....	<b>13</b>
Placing a Service Call .....	13
Obtaining Replacement Parts Under Warranty .....	14
Obtaining Replacement Compressor Under Warranty .....	14
End-of-Life Disposal of Refrigerated Equipment .....	14
<b>Limited Extended Protection Warranty</b> .....	<b>15</b>
<b>Troubleshooting and Servicing Guide</b> .....	<b>16</b>
<b>Wiring Diagrams</b> .....	<b>18</b>

## MILK COOLERS FORCED AIR & COLD WALL

### RECEIVING YOUR NEW MODEL

Congratulations on your purchase of Continental Refrigerator superior foodservice equipment! When your shipment arrives, thoroughly examine the packaging for any punctures, dents or signs of rough handling. It is in your best interest to partially remove or open the shipping container to examine the contents for any missing accessories or concealed damage which may have occurred during shipment. If the cabinet is damaged, it must be noted on the carrier's delivery slip or bill of lading and a Freight Claim must be filed with the shipping company. **FREIGHT DAMAGE IS NOT COVERED UNDER WARRANTY.**

### GENERAL INFORMATION AND IMPORTANT OPERATING FACTS

This manual has been compiled to aid in the installation, operation and maintenance of your equipment. Please read it and familiarize yourself with your equipment, its operation and available accessories, to enjoy optimum performance.

*This equipment is prohibited from use in California with any refrigerants on the "List of Prohibited Substances" for that specific end-use, in accordance with California Code of Regulations, title 17, section 95374. This disclosure statement has been reviewed and approved by NRAC, Inc. and NRAC, Inc. attests, under penalty of perjury, that these statements are true and accurate.*

### SERIAL DATA TAG

A serialized data tag is permanently attached to the inside right-hand wall of your unit. (see **Figure 1**). In addition to identifying the specific product, this label provides important information regarding electrical requirements and refrigeration charge, as well as agency listings and factory contacts.

FIGURE 1: Data Tag

<b>Continental Refrigerator</b> 539 Dunkisferry Road • Bensalem, PA 19020-6908 215-244-1400 • 800-523-7138 • FAX: 215-244-9579 Division of National Refrigeration and Air Conditioning Products, Inc.					
MODEL		SERIAL			
POWER SUPPLY	WIRES	VOLTS		HZ.	PH.
	VOLTS	HERTZ	PHASE	AMPS.	
CABINET COND. UNIT					
DEFROST REFRIGERANT TYPE		AMOUNT OZS.			
DESIGN PRESSURE LIMIT		PSI LOW SIDE	PSI HIGH SIDE		
		COMMERCIAL REFRIGERATOR FREEZER			
 CONFORMS TO U.L. STANDARD 471					
<small>IMPORTANT NOTICE: FOR WARRANTY PARTS AND SERVICE AUTHORIZATION CALL THE SERVICE DEPARTMENT AT 1-800-523-7138</small>					

**IMPORTANT NOTE:** The model and serial number should be noted on the front cover of this manual, in the spaces provided. If parts or service are ever needed for your unit, this information will be required to verify warranty status and to properly identify any parts that may be needed.

All cabinets must be given sufficient time to reach normal operating temperature before placing any pre-chilled milk inside cabinet. Approximately 1 hour of operation is required to lower the cabinet temperature to 38°F (4°C). During pull-down, doors and lids should be kept closed (see "Operation" section for further information).

**IMPORTANT NOTE:** It is strongly recommended that top lids and doors be kept in the closed position when the unit is not in use or between rush periods. This is extremely important during the summer months and in hot kitchens. **Do not** keep the top lids and doors open for prolonged periods of time and **never** operate forced air models for longer than four hours with lids and doors open as evaporator coil can ice and may have to be manually defrosted.

Prior to factory shipping, all products are performance-run tested for a minimum of 12 hours providing a highly sophisticated temperature recording exclusive to each individual cabinet. This recording is supplied within this manual packet. A final evaluation, including analysis of cabinet performance, leak check, vibration, noise level and visual examination is made by a qualified quality control team to assure a superior product. The carrier signs to this effect when they accept the product for shipping. To insure the maximum in safety and sanitation, all models are listed under applicable Underwriters Laboratories and the National Sanitation Foundation standards.

**CAUTION**

**RISK OF ELECTRICAL SHOCK**  
**KEEP ELECTRICAL COMPONENTS AND CONTROLS DRY**  
**- DO NOT SPRAY WITH WATER!**  
**FAILURE TO FOLLOW THESE INSTRUCTIONS CAN CAUSE A HAZARD & VOID FACTORY WARRANTY.**

### UNCRATING YOUR NEW MODEL

The shipping container should remain on your cabinet to avoid dents or scratches while transporting to the actual set-up location. All accessories are carefully packaged and secured inside

your cabinet to prevent damage. After moving unit to its final location, remove all the staples from around the bottom of the crate using a pry bar. Slide the cardboard carton up and off the unit, being careful not to rub against the cabinet. Remove any accessories or boxes on the skid. Dispose of all packaging materials properly.

Your milk cooler comes with the casters pre-installed. Two (2) bolts secure the cabinet to the wooden skid. The bolts are located at each end on the underside of the cabinet. Using a  $\frac{3}{4}$ " socket or open end wrench, remove the bolts. You can now lift the cabinet off the skid, or carefully knock the wood supports off each end of the skid and roll your milk cooler off.

**IMPORTANT NOTE:** Do not under any circumstances, lay your new model on its front or sides. For a brief period of time, you may lay the cabinet on its back, but only when it's properly blocked so as not to crush the back or end panels and also to allow provision for your hands, in order to set it in its upright position without damaging the cabinet. **Do not plug in and operate model for at least three (3) hours after cabinet is set upright from being on its back as this can damage the compressor.**

### INSTALLATION AND LOCATION

Before moving the cabinet to its final point of installation, measure all doorways or passages to assure sufficient clearance.

#### VENTILATION

The final location site of your forced air or cold wall refrigerator must provide a sufficient quantity of cool, clean air. All refrigeration systems operate more efficiently and trouble-free with cool, dry air circulation. Avoid locations near heat and moisture generating equipment including ovens, fryers, dishwashers, steam kettles, etc. Do not install in direct sunlight (where temperatures may exceed 100°F) or in an unheated area (where temperatures may drop below 55°F).

Air supply to the condensing unit is critical. Restricting airflow places excessive heat load on the unit, adversely affecting its operation and may cause premature failure.

**IMPORTANT NOTE:** For maximum efficiency, your new cabinet must be located where an unrestricted air supply can be circulated to the condensing unit. For optimum performance, a minimum clearance of 3" on each side and rear of the cabinet should be provided. Your model has been designed to operate only with the casters supplied. Never obstruct the area below the grill in the front or rear of the cabinet in any way, and never place or store anything inside the cabinet machine compartment. These rules are essential for long life. **FAILURE TO FOLLOW THESE GUIDELINES MAY VOID YOUR WARRANTY.**

#### FLOOR DRAINS AND LOADS

Your milk cooler should be located over top of, or close to, a building floor drain. The floor should provide level positioning, be free of vibration and strong enough to support the total combined weights of your new model plus the maximum product load which might be placed into it. Keep in mind that all the weight is concentrated at the casters. To estimate the possible product weight, assume that each cubic foot of storage space weighs approximately 35 pounds. Multiply 35 pounds by the amount of cubic feet in the cabinet to obtain the product load weight.

*For example, a 20 cubic foot refrigerator can hold approximately 700 pounds of product (35 x 20). Assuming the cabinet itself weighs 300 pounds, the total combined weight of cabinet and product is approximately 1000 pounds. Therefore, the floor in this example must be able to support up to 1000 pounds.*

#### CABINET CLEAN OUT DRAIN AND HOSE

All forced air and cold wall models contain a 1" diameter clean out drain with a drain stopper and 3' long  $\frac{3}{4}$ " ID drain hose. The floor drain is located on the bottom right hand floor in the storage compartment. The external drain connection and hose are accessible behind either the front or rear grill (**see Figure 3 for location**). A flexible hose, attached to the drain line under the cabinet, is located behind the front grill, toward the right hand side (**see Figure 3**). The clean out drain hose should be routed directly to a building floor drain. Never place the hose in the condensate pan of your milk cooler. The hose must be positioned safely so any liquid flows directly into the floor drain and does not spill onto the floor, to avoid any tripping or slipping hazards.

**IMPORTANT NOTE:** It is very important that your milk cooler is properly level during operation. If it is not level, doors won't close properly and gaskets won't provide a good seal, which will cause your unit to run excessively. Excess ice will accumulate inside the cabinet, around the door openings and on the forced air evaporator coil. If allowed to continue, ice will eventually block the coil and the refrigeration system won't be able to maintain proper temperature, resulting in loss of product stored inside. In addition, a cabinet that is not level will allow condensation water to overflow the pan and spill into the storage compartment.

## CONDENSATE PAN (Forced Air Models)

All forced air models have a built-in condensate vaporizer on the underside of the cabinet (see Figure 2A) and are completely self-defrosting. The activator switch is protected by a packing nut during shipment. The nut must be removed for proper operation. Disconnect power by unplugging the cabinet power cord from the supply. Remove the front grill by taking out the 2 screws at each end. Gently pull the grill forward, away from the cabinet, being careful not to damage the tubing from the thermometer to the sensing bulb. Loosen the screws securing the hold down bracket and lift the condensate pan out of the mounting bracket. Remove the packing nut from the switch and discard the nut. Place the condensate pan back in the mounting bracket. Plug the power cord into the receptacle labeled "VAPORIZER" on the control box. Check that the switch is operating correctly by lightly pressing down on the top of the pan, at the end where the cord is attached. You will hear a "click" as pressure is applied and another "click" when pressure is removed. If you do not hear the switch "click", ensure the pan is seated in the bracket correctly and the cord is properly routed and secured in the clamp. Reinstall the grill and reconnect power. To clean the vaporizer, follow the steps above.

**IMPORTANT NOTE:** It is extremely important to ensure the condensate pan is plugged into the receptacle labeled "vaporizer" and that the condensing unit is plugged into the receptacle labeled "condensing unit." **DO NOT** connect the floor drain to the condensate pan. The electric vaporizer is provided to eliminate condensation moisture only. Placing the floor drain hose in the electric vaporizer will create unsanitary and unpleasant odors. Water from the floor drain will also overflow the condensate pan and spill onto the floor, creating unsafe conditions.

FIGURE 2: Electric Condensate Pan (Forced Air Models)

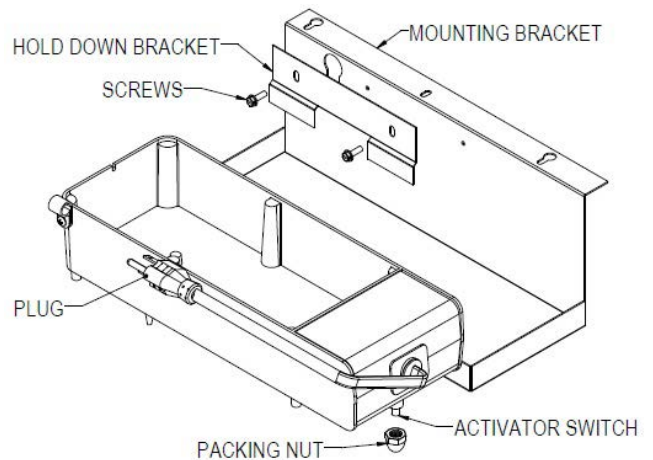
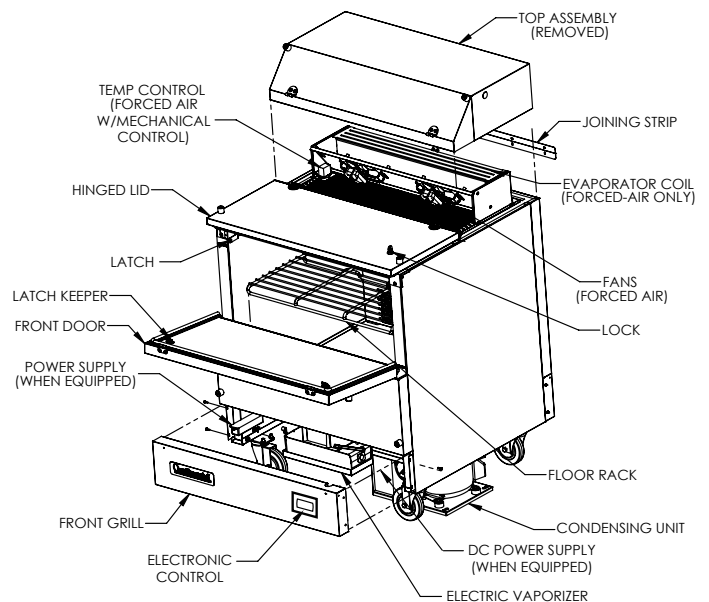
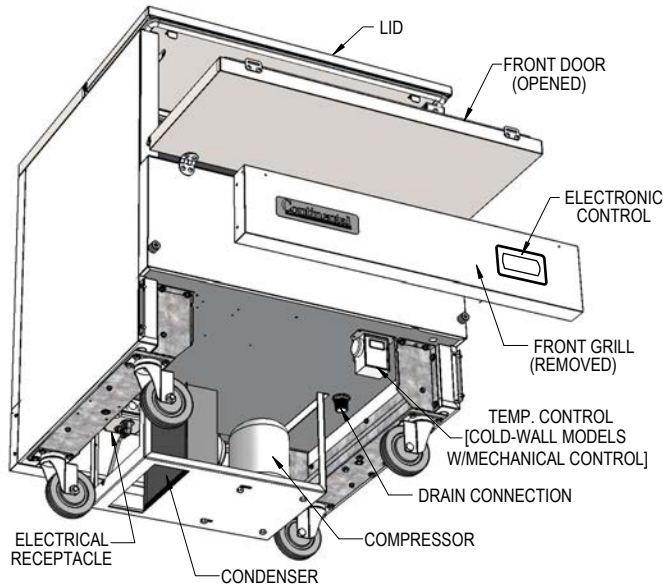

FIGURE 2A: Milk Cooler Components (Forced Air Models)



**FIGURE 3: Milk Cooler Components (Cold-Wall Models)**



**FIGURE 4: Door Latch and Lid Lock**

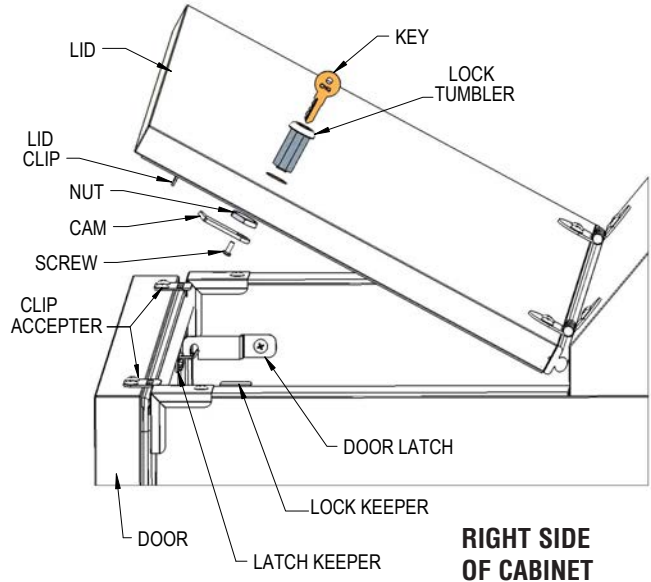

## DOOR LATCH AND LID LOCK

To open your milk cooler, unlock the lid by turning the key so the cam disengages from the keeper (**see Figure 4**). Lift the lid and slowly rotate it back, so it rests against the bumpers. Locate the door latch on the interior side wall. Lift up on the front of the latch and rotate it back, to disengage it from the keeper. The door will now freely rotate down. Lower it gently so it rests against the front bumpers. To close, lift the door back into place and rotate the latch to engage the keeper. Close the lid by rotating forward and lower it into place, so the clips engage into the accepters at each end of the door.

**NOTE:** The lid clips and accepters secure the door, so it cannot be opened until after the lid is unlocked and opened. Always close the door before closing the lid.

## LATCH ADJUSTMENT AND LOCK REPLACEMENT

If the lid or door does not close properly, check alignment of the clips on underside of the lid and the accepters inside the door (**see Figure 4**). To adjust, loosen the screws, move clip or acceptor to position desired and retighten the screws. Use the same method to adjust the latch keeper if needed. To remove the lid lock, start on the inside. Use a large philips screwdriver to turn the lock screw counter-clockwise to loosen it. Remove the screw and cam. Use a large wrench to turn the nut counter-clockwise and remove it. From outside the lid, pull the tumbler out of the hole. To replace the lock, reverse the above steps.

**FIGURE 5: Forced Air Top Removal (Dual Access Model Shown)**

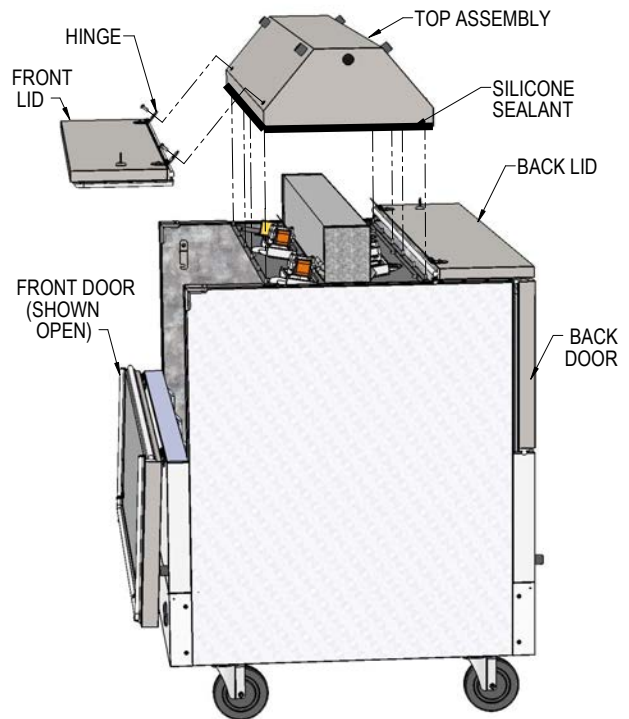



**REMOVAL OF TOP ASSEMBLY** (*Forced Air Models Only*)

The top assembly can be removed, by a qualified technician, to access the evaporator coil, fans and related components (see Figure 5). Removal and replacement will require a Philips screwdriver, razor knife, tube of NSF-approved silicone sealant and a silicone gun. To begin, open the front door and lid. Remove the lid hinge screws from the top assembly. On single access models, remove the joiner strip and screws from the back of the cabinet (see Figure 3). For dual access models, remove the screws from the hinges on the back Lid (see Figure 4). Set the lid(s), hinges and other parts aside. Use a razor knife to carefully score the silicone seal around the base of the top assembly. **BE EXTREMELY CAREFUL** to avoid cutting yourself or scratching your milk cooler. From inside the storage compartment, remove screws from the underside of the top assembly. Gently lift the top assembly straight up and off the cabinet. To reattach the top, clean all excess sealant, reverse the above steps and use silicone to provide an airtight seal between the top and cabinet.

**INTERIOR ACCESSORIES**

The standard interior accessory package that is supplied from the factory with your milk cooler model consists of an epoxy-coated, steel wire floor rack (see Figure 2) which sits on the interior stainless steel floor (MC5 models receive two) with the legs facing down, as shown. A rubber stopper is also provided for the floor drain.

**INITIAL CLEANING PROCEDURE**

Prior to start-up and before placing any product inside of your new model, the interior of the cabinet should be thoroughly cleaned. Remove the protective film (which is clear on some models) from all interior sides, bottom and other internal metal panels, by working the corner loose and slowly pulling the film back. Washing with a mild soap and warm water solution is recommended for cleaning the aluminum and stainless steel surfaces of your cabinet. This should be followed by cleaning with a baking soda solution (three (3) tablespoons of baking soda to each quart of warm water). Wipe down thoroughly with a damp cloth or sponge that has been soaked in clean water and wrung out thoroughly, and dry with a clean, soft cloth.

**IMPORTANT NOTE:** Never use harsh detergents, cleaners, scouring powders or chemicals when cleaning your model. Failure to dry the interior surfaces after cleaning may result in a streaking or staining of the metal.

Complete cleaning procedures and precautions are listed in the (“**Periodic Cleaning Procedure**” under “**Maintenance**”).

**START-UP PROCEDURE****ELECTRICAL CONNECTIONS**

To insure proper operation, your new model must be connected to an individual circuit that can supply the full voltage as stated on the cabinet serial data plate. For correct voltage, power draw, and wire accommodations, check the data on the serial data plate located on the inner right wall of your new model. Verify that this information exactly matches the electrical characteristics at the installation location. An electrical wiring diagram, located on the inside compressor compartment rear, next to the electrical console box, should also be consulted during connection. For reference, a copy of each electrical wiring diagram is located towards the back of this manual (see “**Wiring Diagrams**” section).

Refrigeration compressors are designed to operate within +/-10% of the rated voltage indicated on the cabinet serial plate. Excessively high or low supply power can burnout the compressor. This can be easily detected and will void the factory warranty. Full voltage at the correct rating, on a separate, designated circuit, not affected by the operation of other electrical appliances, must be available to the refrigeration unit at all times. Extension cords should never be used on commercial equipment, as they can overheat and/or result in low voltage.

**GFI/GFCI RECEPTACLES**

Ground-Fault Circuit Interrupter (GFCI or GFI) devices are not recommended for most commercial refrigerators and freezers, since nuisance trips may occur, typically due to moisture. This can cause temporary loss of power, which may result in high storage temperatures and potentially unsafe food product. Building codes in some areas may require certain 115 volt receptacles to be protected by a GFI. If you need to connect your equipment to a protected circuit, a properly sized, commercial grade GFI circuit breaker should be used on a separate, isolated power supply. Or a qualified electrician may be able to hard wire your equipment, eliminating the need for a GFI device. Contact Continental’s Service Department before making any modifications to your cabinet, to avoid loss of warranty.

**NOTE: GFI RECEPTACLES ARE NOT RECOMMENDED, PRODUCT LOSS OR SERVICE PROBLEMS RESULTING FROM NUISANCE TRIPS, CONNECTION TO A DEFECTIVE OR IMPROPER POWER SUPPLY, AND UNAUTHORIZED MODIFICATIONS TO YOUR EQUIPMENT CAN CAUSE A HAZARD AND WILL VOID FACTORY WARRANTY.**

## MILK COOLERS FORCED AIR & COLD WALL

### 115 VOLT, 60 HZ, 1 PHASE CONNECTION

All 115 volt models are provided with a factory installed, UL approved 15-amp power cord and NEMA 5-15P plug, or a 20-amp power cord and NEMA 5-20P plug. To insure proper operation, this equipment must be plugged into a NEMA compatible, grounded receptacle that can supply the full voltage and amperage stated on the serial plate (see Figure 1).



NEMA 5-15P

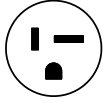

NEMA 5-20P

**IMPORTANT NOTE: A SEPARATE, ISOLATED, PROPERLY SIZED POWER SUPPLY MUST BE PROVIDED. GFCI DEVICES AND/OR EXTENSION CORDS SHOULD NOT BE USED. PRODUCT LOSS, AS WELL AS PROBLEMS RESULTING FROM NUISANCE TRIPS OR HIGH/LOW VOLTAGE, ARE NOT COVERED UNDER WARRANTY.**

### SPECIAL VOLTAGE CONNECTIONS

When models are ordered from the factory with special, optional voltages, connections should be made as required on the electrical wiring diagram provided on the inside compressor compartment rear next to the electrical console box.

### START-UP CHECKLIST

After your unit has been installed and power connected in accordance with this manual, please take time to check the following before loading product, to assure trouble-free operation:

- Cabinet location suitable and unit is level (see “**Installation and Location**”)
- Separate power supply with correct voltage (see “**Electrical Connections**”)
- Drain hose routed to floor drain (see “**Installation and Location**”)
- Vaporizer connected (see “**Evaporator Condensate Removal**”)
- Doors and lids close and seal properly (see “**Door Latch and Lid Lock**”)
- Cold Wall Models: Correct cabinet temperature (see “**Cold Wall Refrigeration System and Adjustment**” or “**Operation with Electronic Control**”)
- Forced Air Models: Correct cabinet temperature (see “**Forced Air Refrigeration System and Adjustment**” or “**Operation with Electronic Control**”)
- Refrigeration lines free of kinks and vibration (see “**Refrigeration System**”)
- All packaging discarded and cabinet cleaned (see “**Periodic Cleaning**”)

The system should run smoothly and quietly in accordance with generally accepted commercial standards. If any unusual noises are heard, turn the unit off immediately and check for obstructions of the condenser or evaporator fans. Fan motors, blades, and housings can be jarred out of position through rough handling in transit.

**CAUTION: IF POWER IS DISCONNECTED FOR ANY REASON, ALLOW 5 MINUTES FOR THE SYSTEM TO EQUALIZE BEFORE TURNING THE UNIT BACK ON. DISREGARDING THIS PROCEDURE MAY CAUSE AN OVERLOAD AND PREVENT THE UNIT FROM OPERATING!**

## OPERATION

### REFRIGERATION SYSTEM AND ADJUSTMENT

*(Cold Wall)*

All self-contained “cold wall” milk cooler refrigerators are designed and factory set to maintain an average cabinet temperature of 36°F. Note that adjusting a cabinet too cold (below the “Cut-In” setting of 30°F) could result in freezing your product over long periods of time. Further adjustments out of the factory design temperature range must be made by a qualified refrigeration mechanic only. The cold wall system operates by wall temperatures reaching below freezing (approximate wall temperature is 20°F) and should periodically be manually defrosted to minimize wall ice accumulation. To manually defrost your milk cooler, unload all product and place it in a refrigerated storage unit. Keep the lids and doors open, and disconnect power to the cabinet (by unplugging the power cord) for approximately 30 minutes allowing the frost to melt and drain to the floor drain. Care should be taken not to scrape and potentially puncture the wall since the refrigeration tubing is located behind the wall and could be damaged.

### REFRIGERATION SYSTEM AND ADJUSTMENT

*(Forced Air)*

All self-contained “forced air” milk cooler refrigerators are designed and factory set to maintain an average cabinet temperature of 36°F. Due to the open-type design and use of milk coolers, it is normal for condensation to periodically form around the door and lid seams and hinges, particularly if the temperature has been set too cold. If moisture becomes excessive check, the control settings (see “**How to Change the Set Point**” on page 9) .

**IMPORTANT NOTE:** All refrigerators are designed with an automatic, “off-cycle” defrost system. Defrosting occurs automatically when the compressor is not operating during an off-cycle. Do not set the thermostat where the cabinet temperature will fall below 34°F because the evaporator will become blocked by ice since the compressor off-cycle will be considerably shortened. This will result in loss of product stored within the cabinet and require service to defrost the evaporator and re-adjust the thermostat, which is not covered under warranty.

**CAUTION: ON ALL “FORCED AIR” AND “COLD WALL” MODELS, IT IS STRONGLY RECOMMENDED THAT TOP LIDS AND DOORS BE KEPT CLOSED WHEN THE UNIT IS NOT IN USE OR BETWEEN RUSH PERIODS. THIS IS EXTREMELY IMPORTANT DURING THE SUMMER MONTHS AND IN HOT KITCHENS. DO NOT KEEP THE TOP LIDS AND DOORS OPEN FOR PROLONGED PERIODS OF TIME AND NEVER OPERATE FORCED AIR MODELS FOR LONGER THAN FOUR HOURS WITH LIDS AND DOORS OPEN AS EVAPORATOR COIL CAN ICE AND MAY HAVE TO BE MANUALLY DEFROSTED.**

## ELECTRONIC CONTROL DISPLAY AND BUTTONS

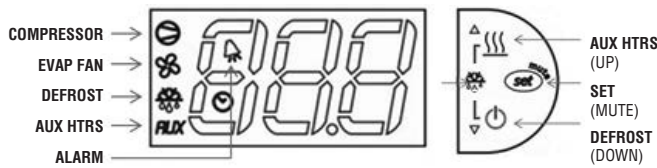

The control has a 3 button interface.

- The “**AUX HTRS/UP**” button is used for adjustment of the auxiliary anti-condensate heaters or for increasing values.
- The “**SET/MUTE**” button is used to lock in a new value or to silence the alarm beeper.
- The “**DEFROST/DOWN**” button is used to activate a manual defrost or for decreasing values.

The control icons shown above will be illuminated when the associated function is active. If an icon is flashing, it means the function will be activated after the controller delays are finished.

**NOTE:** The electronic control has 3 probes. There is the regulation probe in the return air stream, there is an ambient probe, and there is an evaporator probe located in the evaporator coil.

## INITIAL SEQUENCE OF OPERATION

1. Cabinet is plugged in.
  - a. The display will illuminate with the current cabinet temperature.

**NOTE:** If the display does not illuminate, make sure the main power switch on top of the control box is set to **ON** (when provided).

- b. The compressor icon, fan icon, and the aux heater icon may flash for a period of time, indicating normal delayed start-up.
  - c. After the start-up delay, the compressor and evaporator fan(s) will start if the control is calling for cooling. The fan(s) may pulse on and off when the compressor is off to conserve energy.
2. The control will cycle the compressor on and off determined by the SET-POINT and DIFFERENTIAL.
    - a. The SET-POINT is the preprogrammed temperature which shuts off the compressor.
    - b. The DIFFERENTIAL is the preprogrammed temperature that is added to the SET POINT temperature that will start the compressor.

**EXAMPLE:** Set-Point 36°F and the differential is 4°F the compressor will cycle off at 36°F and back on at 40°F.

3. The control may be preprogrammed to initiate a defrost by time interval.
  - a. During defrost, the defrost icon will appear in the display and the compressor will turn off until a preprogrammed temperature or time is reached. During this time for freezers only, the evaporator fan(s) will also turn off and the defrost heater will be energized.
  - b. After a preprogrammed evaporator temperature has been reached, there may be a short delay for both the compressor and evaporator fan(s) to restart.
  - c. After the defrost cycle is completed, the control will resume normal operation.

## HOW TO CALIBRATE THE ELECTRONIC CONTROL

The controller temperature display can be calibrated if required. Before attempting to calibrate the temperature display, check the display by placing a pre-calibrated temperature sensing device in the center of the refrigerated compartment and keep the doors closed for at least 15 minutes. The temperature display should read the same temperature as the sensing device, within +/-2°F. If not, follow these instructions to calibrate.

1. Press and **HOLD** the “SET” button until “PS” appears flashing in the display. Release the “SET” button.

2. Press the “UP” button until “/C1” appears in the display. Release the “UP” button.
3. Press and release the “SET” button. The current value of the offset will appear in the display.
4. Press the “UP” button to increase or the “DOWN” button to decrease the offset value.
5. Press and **HOLD** the “SET” button for 5 seconds to confirm and save the new value. When complete, the current temperature will be displayed. **RELEASE** the “SET” button.

**EXAMPLE:** If a sensing device in the cabinet reads 38°F and the control display shows 41°F, follow steps above and decrease the current offset by 3°F. If the current offset was 0, change to -3.

### HOW TO CHANGE THE SET-POINT

Refrigerators are factory set to maintain an average temperature of 38°F. Freezers are factory set to maintain an average temperature of 0°F. To change set-point:

1. Press and **HOLD** the “SET” button until the current set-point begins flashing. Release the “SET” button.
2. Press the “UP” or “DOWN” button to adjust to the new set-point value.
3. Press and release the “SET” button to lock in the new set-point. The control will now resume normal operation with the new set-point.

### ANTI-CONDENSATE CONTROL

1. To see the current state of the aux heaters (anti-condensate), press and **HOLD** the “AUX HTR” button for 1 second. **RELEASE** the “AUX HTR” button. The display will show the current state of the heater (“ON” or “OFF”) when the button is pressed.
2. To change the current state of the AUX Heaters, press and **HOLD** the “AUX HTR” button. The display will show the current state of heater operation. After 5 seconds, the heater will switch to the opposite state and the display will return to displaying the cabinet temperature. **RELEASE** the button.

The control has a built in energy saving feature for the anti-condensate (AUX) heaters. When set to ON, the heaters will automatically energize when conditions require additional heat, to eliminate condensation. The “AUX” icon on the display will illuminate when the AUX heaters are energized. To maximize energy savings, the AUX heaters can be set to OFF, as described above. In this state, the heaters will never energize. If you ever notice moisture accumulating on the face of your cabinet, adjust the AUX control to ON. This will energize the heaters and warm the face of the cabinet, eliminating any condensation that may accumulate.

### HOW TO INITIATE A MANUAL DEFROST

This is used when a one-time additional defrost may be necessary to clear accumulated ice from the evaporator coil.

1. Press and **HOLD** the defrost button for 5 seconds.
2. After 5 seconds, the defrost icon will illuminate. **RELEASE** the defrost button.

**IMPORTANT NOTE:** During manual defrost, be sure to connect your floor drain to a drainage destination.

### HOW TO CHANGE THE DEFROST INTERVAL

This is used to increase or decrease the frequency of defrosts. If the interval is set at “8”, a defrost will occur every 8 hours. If you need more defrosts, lower this value.

1. Press and **HOLD** the “SET” button until “PS” appears flashing in the display. Release the “SET” button.
2. Press the “UP” button until “DI” (defrost interval) appears in the display. Release the “UP” button.
3. Press and **RELEASE** the “SET” button. The current defrost interval will appear in the display.
4. Press the “UP” or “DOWN” button to adjust to the new defrost interval.
5. Press and **HOLD** the “SET” button to lock in this new value. When the display returns back to cabinet temperature, release the “SET” button.

**NOTE:** Defrost cycles are time initiated and temperature terminated with a maximum time cut-off.

### HIGH AND LOW TEMPERATURE ALARMS

The controller has high and low alarm set-points. These values can be modified per the end user requirements. There is a pre-programmed time delay for the alarm to activate to eliminate nuisance alarms. To change the alarm threshold values:

1. Press and **HOLD** the “SET” button until “PS” appears flashing in the display. Release the “SET” button.
2. Press the “UP” button until “AL” (Low Alarm Setting) or “AH” (High Alarm Setting) appears in the display. Release the “UP” button.
3. Press and **RELEASE** the “SET” button. The current alarm setting will be shown.
4. Press the “UP” or “DOWN” button to get the desired alarm set-point.
5. Press and **HOLD** the “SET” button for 5 seconds to confirm and save the new value. When complete, the current temperature will be displayed. Release the “SET” button.

**NOTE:** When in an alarm condition, the display will alternate between the cabinet temperature and alarm code. “AL” when in a low temperature alarm condition and “AH” when in a high temperature alarm condition. The control will also beep and the alarm icon will activate when in an alarm condition. To silence the alarm beeper for the active alarm just press and release the “SET/MUTE” button.

## ELECTRONIC CONTROL ERROR CODES

When in an alarm condition, the display will alternate between the alarm code and the current cabinet temperature. The alarm icon will also illuminate and the beeper will activate. If there is a regulation probe error, the display will just show alarm code “E0” and not flash the cabinet temperature. **If there is a probe error, you must contact your service provider immediately.**

Alarm Code	Alarm Description	Notes
E0	Regulation Probe Error	Located in return air stream
E1	Evaporator Probe Error	Located in evaporator coil
E2	Ambient Probe Error	Located on side of electrical box
LO	Low Temperature Alarm	Reference “AL” parameter
HI	High Temperature Alarm	Reference “AH” parameter

- Error code “E0”: The control will operate the appliance in a preprogrammed ON/OFF cycle based on time, not temperature.
- Error code “E1”: The control will still go into a defrost but will terminate on time, not temperature.
- Error code “E2”: The aux heaters will not operate.
- If the control goes into a high/low temperature alarm, the beeper will sound and alarm icon will illuminate. When the temperature goes below the alarm threshold for high temperature alarms or above the alarm threshold for low temperature alarms, the control will go back to normal display.

## MAINTENANCE

### SAFETY PRECAUTIONS

**DISCONNECT POWER BEFORE ATTEMPTING TO WORK ON OR CLEAN EQUIPMENT. DO NOT ATTEMPT TO REMOVE ANY COVERS OR PARTS YOURSELF, AS THIS CAN EXPOSE DANGEROUS, HIGH VOLTAGE WIRING. SERVICE SHOULD ONLY BE PERFORMED BY A QUALIFIED TECHNICIAN.**

**ALWAYS ROUTE POWER CORDS AWAY FROM AREAS WHERE THEY CAN BE WALKED ON OR DAMAGED BY OTHER EQUIPMENT. YOUR APPLIANCE IS EQUIPPED WITH A POLARIZED, GROUNDED POWER PLUG. NEVER ATTEMPT TO REMOVE THE GROUND POST OR USE A NON-POLARIZED ADAPTER, WITHOUT PROPERLY GROUNDING THE EQUIPMENT.**

**CONDENSER FINS ARE MADE FROM THIN METAL AND HAVE SHARP EDGES. ALWAYS WEAR GLOVES AND USE CAUTION WHEN WORKING ON OR AROUND THE CONDENSING UNIT TO PREVENT CUTS AND AVOID DAMAGING FINS, TUBING AND OTHER COMPONENTS.**

**KEEP ELECTRICAL COMPONENTS AND CONTROLS DRY. DO NOT SPRAY WITH WATER! FAILURE TO FOLLOW THESE INSTRUCTIONS CAN CAUSE A SAFETY HAZARD AND VOID FACTORY WARRANTY.**

### PERIODIC CLEANING PROCEDURE

It is always best to clean your refrigerator or freezer when the product load in your cabinet is at its lowest level. To clean the interior or exterior cabinet surfaces, follow these procedures:

1. Disconnect your cabinet from its power supply and remove all product from inside.
2. Open all doors and allow the cabinet to reach room temperature. Remove all accessories (floor racks, drain plug stopper, etc.) from inside and wash them with a baking soda and warm water solution, wipe thoroughly with clean water. Dry all accessories completely with a soft clean cloth.
3. Once the cabinet has reached room temperature, wash the inside and outside surfaces with a solution of warm water and baking soda. Pay particular attention to the face of the cabinet, as any residue or debris can impair the door seal. For slightly more difficult cleanups, ammonia or vinegar in warm water can be used. Wipe down thoroughly with a damp cloth or sponge that has been soaked in clean water.

and wrung out thoroughly, and dry with a clean, soft cloth. Carefully wash all of the vinyl door gaskets with clean water, dry them and check for any damage, which may affect the seal. Failure to dry all surfaces completely may cause water stains or streaking on the aluminum or stainless steel finish.

- Return all accessories to their original locations, reconnect the power. Wait at least 1 hour before reloading product.

## CLEANING PRECAUTIONS

**NEVER USE HARSH DETERGENTS, ABRASIVE CLEANERS, OR CHEMICALS CONTAINING HALOGENS (CHLORINE, FLUORINE, IODINE, ETC.) WHEN CLEANING YOUR UNIT. CONCENTRATED CHEMICALS CAN CAUSE DISCOLORING, ALWAYS WIPE THEM OFF IMMEDIATELY IF CONTACT OCCURS. SEE "CLEANING OF STAINLESS STEEL" FOR MORE INFORMATION. AVOID SPLASHING THE CABINET WITH WATER AND CHEMICALS WHEN MOPPING FLOORS OR CLEANING OTHER EQUIPMENT AROUND IT.**

## GENERAL PREVENTATIVE MAINTENANCE

The most important thing you can do to maintain any refrigerator or freezer and extend its life, is to keep the condenser clean. Performance of the air-cooled condensing unit, located under the cabinet, depends exclusively upon the amount of air passing through the condenser fins. Your refrigerator or freezer will run more efficiently, consume less energy, and provide a maximum of trouble-free service throughout its lifetime if the condenser coil is kept clean and an adequate supply of clean, cool air is provided at all times. Periodically (at least once a month) it is important to inspect the condenser coil for any debris or blockage that may have accumulated.

If the condenser coil is dirty or dusty, disconnect the cabinet power supply and use a stiff brush to wipe away any dirt and debris from the condenser fins. Using a vacuum cleaner with a brush attachment may aid in this process. After cleaning, restore electrical service to your cabinet.

## IMPORTANT!

**AFTER-MARKET CONDENSER FILTERS ARE NOT PERMITTED BECAUSE THEY HINDER AIRFLOW. FAILURE TO KEEP THE CONDENSER CLEAN AND FREE FROM OBSTRUCTIONS WILL CAUSE EXCESSIVE COMPRESSOR LOAD, REDUCING THE PERFORMANCE OF YOUR UNIT. THIS CAN RESULT IN PREMATURE FAILURE AND WILL VOID YOUR WARRANTY.**

## CARE AND CLEANING OF STAINLESS STEEL\*

\*Some information and graphics for this section were obtained from "Stainless Steel Equipment Care and Cleaning" brochure, published by the North American Association of Food Equipment Manufacturers (NAFEM).

Contrary to popular beliefs, stainless steel can rust, if not properly cared for and maintained (That's why it's called stain-LESS steel, not stain-PROOF steel.)

All steel is primarily made of iron. Stainless steels contain other metals, such as chromium and nickel, that provide an invisible film on the surface of the steel that acts as a shield against corrosion. As long as this invisible layer is intact and not broken or contaminated, the metal will retain its corrosion protection and remain stain-less.

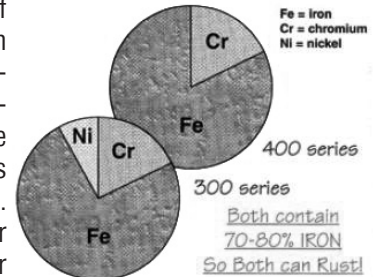

**There are 3 basic things that can break down the protective layer on your stainless steel, which must be avoided:**

- MECHANICAL ABRASION** is caused by things that scratch the surface of the metal. Only use soft cloths or plastic scouring pads to clean and always scrub in the same directions as the metal grain.

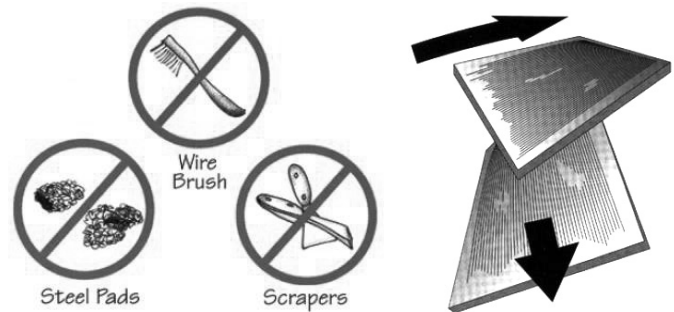

**DO NOT USE: steel pads, wire brushes, scrapers or knives to clean your equipment.**

- CHLORIDES** are found in water, salt, food and worst of all, many cleaners. Only use chloride-free, alkaline-based, non-abrasive cleaners. Always wipe thoroughly with cool, clean water and dry with a soft towel. A solution of 1 tablespoon baking soda mixed with 1 pint water can be used to remove tough stains.



**DO NOT USE:** abrasive cleaners, chemicals with chlorides or muriatic acid to clean your equipment.

- HARD WATER** causes spots and stains on stainless steel surfaces, particularly when it is heated. Find out the hardness of your water and treat it properly, if needed. Use a water filter and softeners if you have hard water. Club soda can be used to remove streaks or spots.

### U.S. WATER HARDNESS MAP

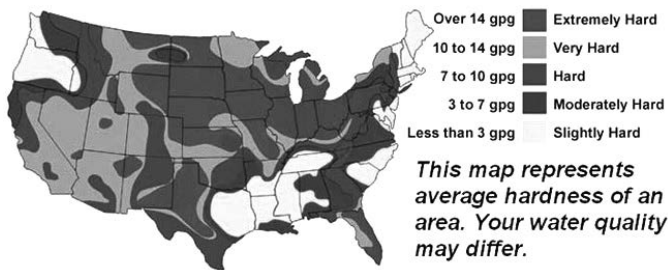

**DO NOT USE:** hot or hard water to clean stainless steel.

**CLEAN YOUR STAINLESS STEEL REGULARLY** using the proper tools and cleaners. After cleaning, always **wipe, wipe, wipe** thoroughly with **cool, clean, clear water**.

**CHECK ALL OF YOUR EQUIPMENT PERIODICALLY.** If you see any signs of rust, clean the area immediately, with a plastic scrubbing pad. If surface rust is removed promptly, permanent corrosion, pits and cracks may be avoided. Special stainless steel polishes, that can help restore the protective coating on your equipment, are available from a variety of retailers.

**IMPORTANT:** If these recommendations are not followed, the protective film on your stainless steel can break down and your equipment may begin the long walk down the dark road of corrosion.

## PARTS AND SERVICE

Continental is committed to providing the best customer service in the industry. All new units come with a Limited Extended Protection Warranty (see **“Warranty”** section of this manual for details). If a problem arises with your equipment, please contact our Service Department at **1-800-523-7138**. One of our Service Specialists will do everything possible to solve the problem as quickly as possible.

### ITEMS NOT COVERED UNDER WARRANTY INCLUDE, BUT ARE NOT LIMITED TO:

- **Preventative maintenance:** cleaning condenser coils and other components.
- **Consumables:** light bulbs, door gaskets, batteries.
- **General hardware adjustments:** cabinet leveling, casters/legs, doors/hinges.
- **Problems due to:** inadequate installation or supply power; improper maintenance, operation, or abuse.
- **Compressor failure due to:** dirty condenser, insufficient clearance/ventilation, excessive temperatures.
- **System adjustments and calibrations, including:** controls, thermometer and expansion valves.

**Consult the Table of Contents in the front of this manual for detailed information on the items listed above. Contact Continental’s Service Department with any additional questions.**

### PLACING A SERVICE CALL

In order to receive prompt service, always be prepared to provide your: cabinet model and serial number; cabinet location name and date installed; contact name and phone number; plus a description of the problem.

During normal business hours (Monday to Friday, 8am to 5pm Eastern) contact the Service Department at: **800-523-7138**, **prior to any warranty service work being performed.**

After normal business hours, or on weekends you can notify our Service Department by sending an email to: [continentalservice@nrac.com](mailto:continentalservice@nrac.com) or by calling **267-525-3300** and leaving a message in the general mail box. Be sure to provide the information listed above. Contact Continental Refrigerator the following business day, during normal business hours, to verify the status of your call.

### OBTAINING REPLACEMENT PARTS UNDER WARRANTY

If replacement parts are required for a unit under warranty, contact Continental's Service Department. New parts will be sent from the factory and, when applicable, a Return Goods Authorization (RGA) will be issued to return old parts. The RGA number must appear on the packaging of any parts returned, or they will not be accepted. If a service agent uses a part from their stock, Continental will replace it with a factory part.

### OBTAINING REPLACEMENT COMPRESSOR UNDER WARRANTY

If the compressor should fail within the first twelve (12) months of use, or within twenty (20) months from the date code on the compressor, an "over-the-counter" exchange must be made at an authorized Copeland, Danfoss, Embraco, or Tecumseh wholesaler.

After the first year, the compressor motor is covered under an extended "parts only" warranty. The customer is responsible for any labor charges and any additional parts that may be required. Contact the Service Department to obtain a replacement compressor through one of the following methods:

- Continental will supply a replacement compressor at no charge and pay for regular freight. (If expedited freight is requested, the end user, dealer or service agent is responsible for additional charges and must provide credit card information.
- A compressor can be purchased locally and Continental will either replace the stock unit with a new factory compressor, or offer an allowance towards the purchase of a replacement compressor, up to: \$100 for 1/5hp to 1/3hp; \$250 for 1/2hp to 3/4hp; \$350 for 1hp to 2hp.

The data tag from the defective compressor (or compressor model, serial number and date code, if the tag cannot be removed) must be included with any reimbursement request.

### END-OF-LIFE DISPOSAL OF REFRIGERATED EQUIPMENT

Your unit is designed and built to provide many years of reliable service. At the end of its useful life, please follow the steps below for safe disposal, to help avoid accidents and to protect the environment.

1. Remove all doors, to eliminate any potential for accidental child entrapment.
2. All refrigerant should be removed from the system by a qualified technician and disposed of properly, or reclaimed. (Intentional venting of many refrigerants into the air is harmful and prohibited; violators are subject to fines). All refrigerant oil should be drained from the compressor and discarded appropriately.
3. Properly dispose of the cabinet and refrigeration system components. The majority of the metal in your unit (stainless steel or aluminum cabinet shell and doors, steel shelving and compressor, copper refrigerant lines, etc.) can be recycled. Many recycling facilities will dispose of the unit free of charge, or pay you for scrap value of the material content.



# Continental<sup>®</sup>

## Refrigerator

### THREE (3) YEAR PARTS AND LABOR WARRANTY

Continental Refrigerator warrants to the original purchaser of every new Continental Refrigerator self contained unit, including all parts thereof, that such equipment is free from defects in material and workmanship, under normal use, proper maintenance and service as indicated by Continental Refrigerator installation and operation manual, for a period of three (3) years from the date of installation, or thirty-nine (39) months from the date of shipment from the manufacturer, whichever comes first. Normal wear type parts, such as light bulbs/lamps and gaskets are not covered by this warranty. For the purpose of this warranty, the original purchaser shall be deemed to mean the individual or company for whom the product was originally installed.

Continental Refrigerators obligation under this warranty shall be limited to repairing or replacing, including labor, any part of such product which proves thus defective. Continental Refrigerator reserves the right to examine any product claimed to be defective. The labor warranty shall be for self-contained units only and for standard straight time, which is defined as normal service rate time, for service performed during normal working hours. Any service requested outside of a servicer's normal working hours will be covered under this warranty for the normal rate and any additional overtime rate will be the responsibility of the equipment purchaser.

Any part determined to be defective in the product should be returned to the company within thirty (30) days under the terms of this warranty and must be accompanied by the cabinet model, serial number, and identified with a return material authorization number, issued by the manufacturer.

Special installation/applications, including remote locations, are limited in coverage by this warranty. Any installation that requires extra work, and/or travel, to gain access to the unit for service is the sole responsibility of the equipment purchaser.

Improper operation resulting from factors, including but not limited to, improper or negligent cleaning and maintenance, low voltage conditions, inadequate wiring, and accidental damage are not manufacturing defects and are strictly the responsibility of the purchaser.

Condenser coils must be cleaned at regular intervals. Failure to do so can cause compressor malfunction and will void warranty. Continental Refrigerator recommends a minimum monthly cleaning, as stated in the installation and operation manual.

### ADDITIONAL TWO (2) YEAR COMPRESSOR PART WARRANTY

In addition to the warranty set forth above, Continental Refrigerator warrants the hermetically/semi-hermetically sealed compressor (part only) for an additional two (2) years beyond the first three (3) year warranty period; not to exceed sixty-three (63) months from the date of shipment from Continental Refrigerator, provided upon receipt of the compressor, manufacturer examination shows the sealed compressor to be defective. This extended warranty does not cover freight for the replacement compressor or freight for return of the failed compressor. Also, this extended compressor-part only warranty does not apply to any electrical controls, condenser, evaporator, fan motors, overload switch, starting relay, capacitors, temperature control, filter/drier, accumulator, refrigeration tubing, wiring harness, labor charges, or supplies which are covered by the standard warranty above.

THE FOREGOING WARRANTIES ARE EXPRESSLY GIVEN IN LIEU OF ALL OTHER WARRANTIES, EXPRESS, IMPLIED, OR STATUTORY, INCLUDING THE IMPLIED WARRANTIES OF MERCHANTABILITY AND FITNESS FOR A PARTICULAR PURPOSE, WHICH ARE HEREBY DISCLAIMED, ALONG WITH ALL OTHER OBLIGATIONS OR LIABILITIES ON OUR PART. AND WE NEITHER ASSUME, NOR AUTHORIZE ANY OTHER PERSON TO ASSUME FOR US, ANY OBLIGATION OR LIABILITY IN CONNECTION WITH THE SALE OF SAID REFRIGERATION UNITS OR ANY PARTS THEREOF.

This warranty shall not be assignable and shall be honored only in so far as the original purchaser.

This warranty does not apply outside the limits of the United States of America and Canada, nor does it apply to any part that has been subject to misuse, neglect, alteration, accident, or to any damage caused by transportation, flood, fire, acts of terrorism, or acts of God.

IN NO EVENT SHALL CONTINENTAL REFRIGERATOR BE LIABLE FOR CONSEQUENTIAL, SPECIAL OR PUNITIVE DAMAGES. THE REMEDIES OF PURCHASER SET FORTH HEREIN ARE EXCLUSIVE AND THE TOTAL LIABILITY OF CONTINENTAL REFRIGERATOR, WHETHER BASED ON CONTRACT, WARRANTY, NEGLIGENCE, INDEMNIFICATION, STRICT LIABILITY, TORT, OR OTHERWISE, SHALL NOT EXCEED THE PURCHASE PRICE OF THE COMPONENT UPON WHICH LIABILITY IS BASED. CONTINENTAL REFRIGERATOR SHALL HAVE NO OBLIGATION OR LIABILITY FOR CONSEQUENTIAL OR SPECIAL DAMAGES, INCLUDING BUT NOT LIMITED TO INDIRECT, PUNITIVE DAMAGES, LOSS OF USE, LOSS OF PRODUCT, DOWNTIME OR LOST PROFITS, ARISING OUT OF, RELATED TO OR CONNECTED IN ANY WAY WITH THE PRODUCT OR ITS USE.

*A Division of National Refrigeration & Air Conditioning Products, Inc.*  
 539 Dunksferry Road • Bensalem, PA 19020-5908  
 P 215-244-1400 • 1-800-523-7138 • F 215-244-9579  
[www.continentalrefrigerator.com](http://www.continentalrefrigerator.com)

## MILK COOLERS FORCED AIR & COLD WALL

### TROUBLESHOOTING GUIDE

PROBLEM	PROBABLE CAUSE	CORRECTION
Condensing unit will not start - no hum.	<ol style="list-style-type: none"> <li>1. Line disconnected, switch open.</li> <li>2. Fuse removed or blown.</li> <li>3. Overload protector blown.</li> <li>4. Control "Off" due to cold location.</li> <li>5. Control stuck in open position.</li> <li>6. Wiring improper or loose.</li> </ol>	<ol style="list-style-type: none"> <li>1. Close start or disconnect switch.</li> <li>2. Replace Fuse.</li> <li>3. Determine reason and correct/replace.</li> <li>4. Relocate control.</li> <li>5. Repair or replace control.</li> <li>6. Check wiring against diagram.</li> </ol>
Condensing unit will not start - hums but trips on overload protector.	<ol style="list-style-type: none"> <li>1. Improperly wired.</li> <li>2. Low voltage to unit.</li> <li>3. Starting capacitor defective.</li> <li>4. Relay failing to close.</li> <li>5. Compressor motor has a shorted or open winding.</li> <li>6. Internal mechanical trouble in compressor.</li> <li>7. Insufficient air supply.</li> </ol>	<ol style="list-style-type: none"> <li>1. Check wiring against diagram.</li> <li>2. Determine reason and correct.</li> <li>3. Determine reason and replace.</li> <li>4. Determine reason and replace.</li> <li>5. Replace compressor.</li>   <li>6. Replace compressor.</li> <li>7. Clear condenser and allow compressor to cool down.</li> </ol>
Condensing unit starts and runs, but short cycles on overload protector.	<ol style="list-style-type: none"> <li>1. Additional current passing through overload protector.</li> <li>2. Low voltage unit.</li> <li>3. Overload protector defective.</li> <li>4. Run capacitor defective.</li> <li>5. Excessive discharge pressure.</li>   <li>6. Excessive suction pressure.</li> <li>7. Insufficient air supply.</li> </ol>	<ol style="list-style-type: none"> <li>1. Check wire diagram. Check for added components connected to wrong side of overload protector.</li> <li>2. Determine reason and correct.</li> <li>3. Check current, replace protector.</li> <li>4. Determine reason and replace.</li> <li>5. Check ventilation, restrictions in cooling medium or refrig. system.</li> <li>6. Check for misapplication.</li> <li>7. Clear condenser and allow compressor to cool down.</li> </ol>
Condensing unit starts, but fails to switch off of "start" winding.	<ol style="list-style-type: none"> <li>1. Improperly wired.</li> <li>2. Low voltage to unit.</li> <li>3. Relay failing to open.</li> <li>4. Run capacitor defective.</li> <li>5. Excessively high discharge pressure.</li>   <li>6. Compressor motor has a shorted or open winding.</li> <li>7. Internal mechanical trouble in compressor.</li> </ol>	<ol style="list-style-type: none"> <li>1. Check wiring against diagram.</li> <li>2. Determine reason and correct.</li> <li>3. Determine reason and replace.</li> <li>4. Determine reason and replace.</li> <li>5. Check discharge shut-off valve, possible overcharge.</li> <li>6. Replace compressor.</li>   <li>7. Replace compressor.</li> </ol>
Condensing unit runs, but short cycles on:	<ol style="list-style-type: none"> <li>1. Overload protector.</li> <li>2. Thermostat.</li> <li>3. High pressure cut-out due to:                             <ol style="list-style-type: none"> <li>(a) Insufficient air supply.</li> <li>(b) Overcharge.</li> <li>(c) Air in system.</li> </ol> </li> <li>4. Low pressure cut-out due to:                             <ol style="list-style-type: none"> <li>(a) Valve leak.</li> <li>(b) Undercharge.</li> <li>(c) Restriction in expansion device.</li> </ol> </li> </ol>	<ol style="list-style-type: none"> <li>1. Check current, replace protector.</li> <li>2. Differential setting must be widened.</li> <li>3.                             <ol style="list-style-type: none"> <li>(a) Check air supply to condenser.</li> <li>(b) Evacuate and re-charge.</li> <li>(c) Evacuate and re-charge.</li> </ol> </li> <li>4.                             <ol style="list-style-type: none"> <li>(a) Replace, evacuate and re-charge.</li> <li>(b) Evacuate and re-charge.</li> <li>(c) Replace expansion device.</li> </ol> </li> </ol>
Condensing unit runs, but for prolonged periods or continuous.	<ol style="list-style-type: none"> <li>1. Shortage of refrigerant.</li> <li>2. Control contacts stuck closed.</li> <li>3. Excessive heat load placed into cabinet.</li> <li>4. Prolonged or too frequent door openings.</li>   <li>5. Evaporator coil iced.</li> <li>6. Restriction in refrigeration system.</li> <li>7. Dirty condenser.</li> <li>8. Filter drier clogged.</li> </ol>	<ol style="list-style-type: none"> <li>1. Fix leak, evacuate and re-charge.</li> <li>2. Clean contacts or replace control.</li> <li>3. Allow unit sufficient time for removal of latent heat.</li> <li>4. Plan or organize schedule to correct condition.</li> <li>5. Defrost evaporator coil.</li> <li>6. Determine location and remove.</li> <li>7. Clean condenser coil.</li> <li>8. Replace, evacuate and re-charge.</li> </ol>

PROBLEM	PROBABLE CAUSE	CORRECTION
Start capacitor open, shorted or blown.	<ol style="list-style-type: none"> <li>1. Relay contact not opening properly.</li> <li>2. Prolonged operation on start cycle:                             <ol style="list-style-type: none"> <li>(a) Low voltage to unit.</li> <li>(b) Improper relay.</li> <li>(c) Starting load too high.</li> </ol> </li> <li>3. Excessive short cycling.</li> <li>4. Improper capacitor.</li> </ol>	<ol style="list-style-type: none"> <li>1. Clean contacts or replace relay.</li> <li>2.                             <ol style="list-style-type: none"> <li>(a) Determine reason and correct.</li> <li>(b) Replace with correct relay.</li> <li>(c) Correct by using pump down.</li> </ol> </li> <li>3. See "Condensing Unit Short Cycles" above.</li> <li>4. Determine correct size and replace.</li> </ol>
Run capacitor open, shorted or blown.	<ol style="list-style-type: none"> <li>1. Improper capacitor.</li> <li>2. Excessively high line voltage, over 110% of rated maximum.</li> </ol>	<ol style="list-style-type: none"> <li>1. Check size and replace.</li> <li>2. Determine reason and correct.</li> </ol>
Relay defective or blown out.	<ol style="list-style-type: none"> <li>1. Incorrect Relay.</li> <li>2. Incorrect mounting angle.</li> <li>3. Voltage too low or too high.</li> <li>4. Excessive short cycling.</li> <li>5. Loose or vibrating mounting position.</li> <li>6. Incorrect run capacitor.</li> <li>7. Loose wiring on relay or overload.</li> </ol>	<ol style="list-style-type: none"> <li>1. Check relay and replace.</li> <li>2. Remount relay in correct position.</li> <li>3. Determine reason and correct.</li> <li>4. See "Condensing Unit Short Cycles" above.</li> <li>5. Remount rigidly.</li> <li>6. Replace with proper capacitor.</li> <li>7. Tighten all wiring screws.</li> </ol>
Product zone temperature too high.	<ol style="list-style-type: none"> <li>1. Control setting too high.</li> <li>2. Inadequate air circulation.</li> <li>3. Dirty condenser.</li> </ol>	<ol style="list-style-type: none"> <li>1. Adjust T-stat.</li> <li>2. Rearrange product load to improve air circulation.</li> <li>3. Clean condenser coil.</li> </ol>
Suction line frosted or sweating.	<ol style="list-style-type: none"> <li>1. Overcharge of refrigerant.</li> <li>2. Evaporator fan not running.</li> <li>3. Expansion valve stuck open.</li> <li>4. Expansion valve superheat too low.</li> </ol>	<ol style="list-style-type: none"> <li>1. Evacuate and re-charge.</li> <li>2. Determine reason and correct.</li> <li>3. Clean valve, evacuate and re-charge.</li> <li>4. Adjust superheat to required setting.</li> </ol>
Liquid line frosted, cold or sweating.	<ol style="list-style-type: none"> <li>1. Restriction in drier strainer.</li> <li>2. Liquid line service valve partially closed.</li> </ol>	<ol style="list-style-type: none"> <li>1. Replace drier, evacuate and re-charge.</li> <li>2. Open valve fully or replace if necessary.</li> </ol>
Noisy condensing unit.	<ol style="list-style-type: none"> <li>1. Loose parts or mounting.</li> <li>2. Tubing rattle or vibration.</li> <li>3. Bent fan blade causing excessive vibration.</li> <li>4. Fan bearings worn.</li> </ol>	<ol style="list-style-type: none"> <li>1. Tighten all mounting parts and shroud cover.</li> <li>2. Reform tubing to be free of contact.</li> <li>3. Replace fan blade.</li> <li>4. Replace fan motor.</li> </ol>
Thermometer reads different than actual temperature.	<ol style="list-style-type: none"> <li>1. Calibration.</li> <li>2. Defective.</li> </ol>	<ol style="list-style-type: none"> <li>1. Consult Operations Manual and calibrate.</li> <li>2. Replace.</li> </ol>
Water leak inside unit.	<ol style="list-style-type: none"> <li>1. Condensate drain pan not installed properly.</li> <li>2. Unit not level.</li> <li>3. Drain pan misaligned.</li> <li>4. Defective drain pan.</li> </ol>	<ol style="list-style-type: none"> <li>1. Consult Operations Manual for install instructions.</li> <li>2. Make sure unit is level or pitched back slightly.</li> <li>3. Make sure drain pan is aligned properly.</li> <li>4. Replace.</li> </ol>
Doors misaligned.	<ol style="list-style-type: none"> <li>1. Shifted during shipping.</li> </ol>	<ol style="list-style-type: none"> <li>1. Refer to Operation Manual for hinge adjustment.</li> </ol>

**MILK COOLERS (FORCED AIR & COLD WALL MODELS) 115/60/1  
WD-R5 WIRING DIAGRAM**

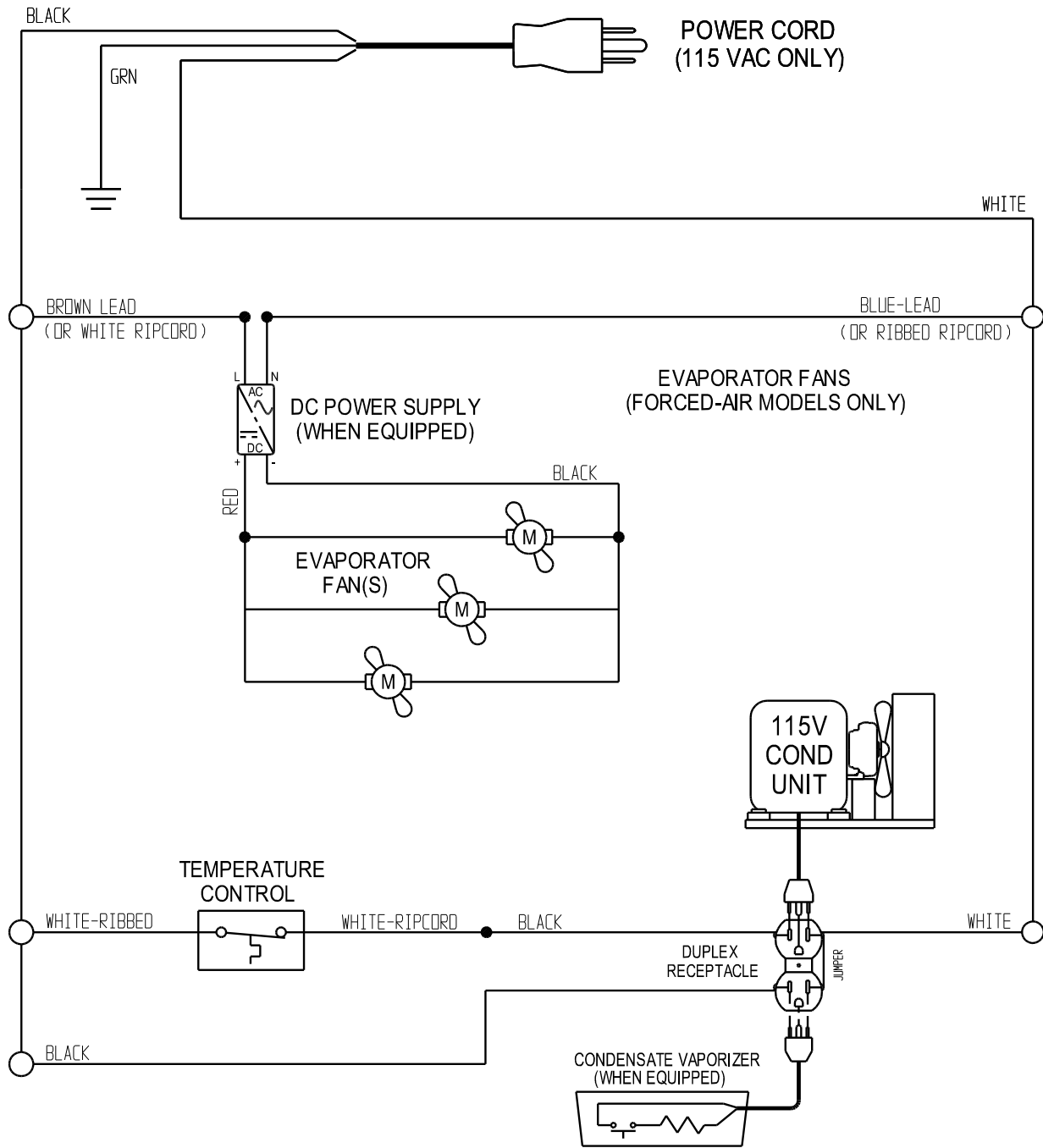

MILK COOLERS (FORCED AIR & COLD WALL MODELS) 115/60/1  
W/ELECTRONIC CONTROL WD-R5-EC WIRING DIAGRAM

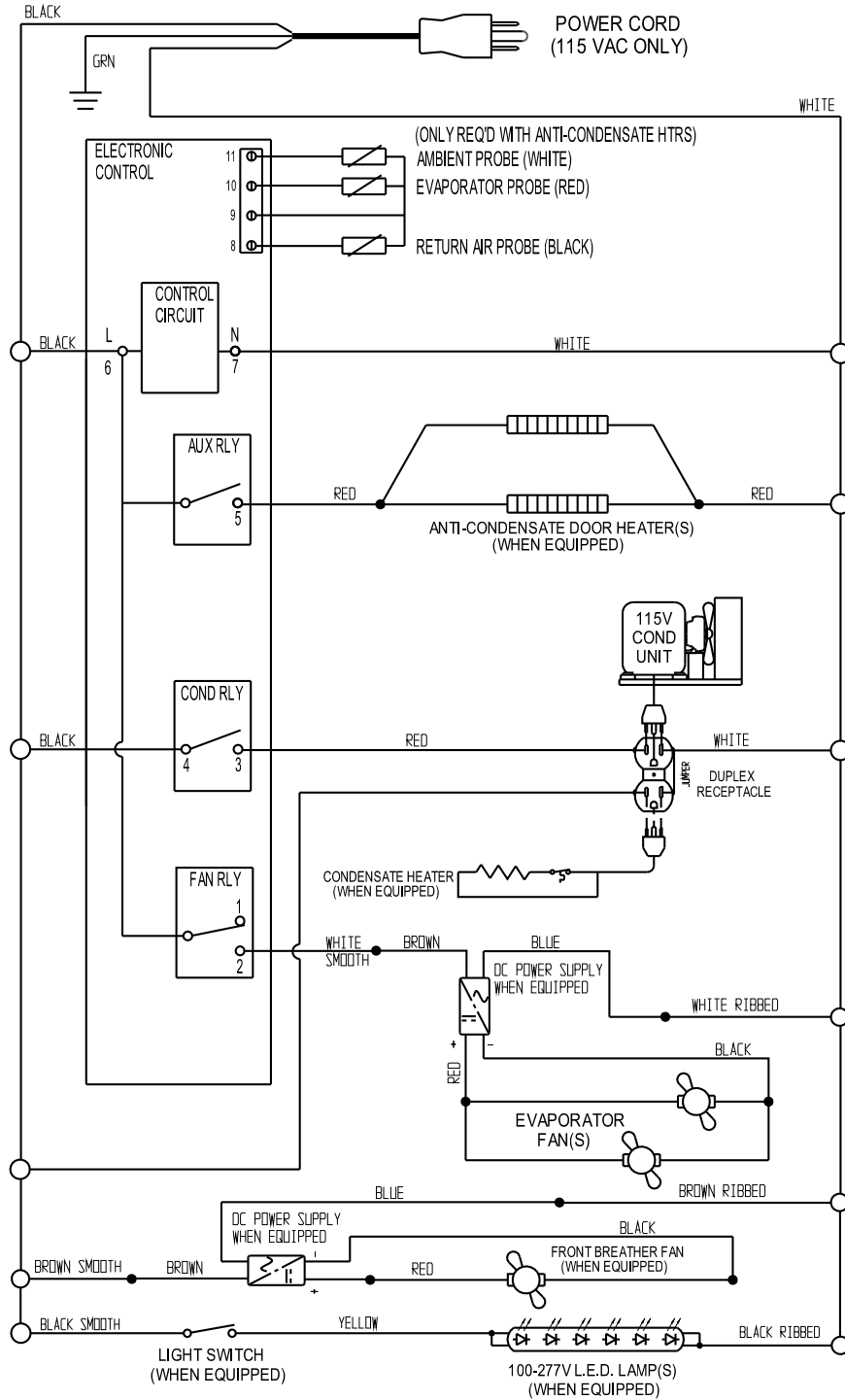





# Continental<sup>®</sup>

Refrigerator

*A Division of National Refrigeration & Air Conditioning Products, Inc.*  
539 Dunksferry Road • Bensalem, PA 19020-5908  
P 215-244-1400 • 1-800-523-7138 • F 215-244-9579  
[www.continentalrefrigerator.com](http://www.continentalrefrigerator.com)

