

BACK BAR EQUIPMENT

Model: BB50NSGDPT

Natural Refrigerant R-290 Model

50" Back Bar Display Pass-Thru Cooler with Sliding Glass Doors

Textured baked black enamel finish exterior, stainless steel countertop, interior back and side panels with reinforced stainless steel floor.



Options and Accessories

(upcharge and lead times may apply)

Additional epoxy coated shelves	Food storage rated stainless steel interior (NSF-7)
Stainless steel shelves	Casters or legs
Wine rack	Compressor right (standard on left)
Riser base*	Slide-guard lock

Consult factory for other model configurations, options and accessories.

* Adding a Riser Base increases overall height 2"

Continental
Refrigerator



Project Name:

Model Specified:

Location:

Item No:

Quantity:

AIA #:

SIS #:

Standard Model Features

REFRIGERATION SYSTEM

Performance rated front breathing refrigeration system

Natural, environmentally safe, high efficiency R-290 refrigerant¹

Automatic, hot gas condensate evaporator

Extra large, balanced evaporator coil

CABINET ARCHITECTURE

High density, non-CFC polyurethane foamed-in-place insulation

Front, rear and side venting louvered grills

Double pane, tempered low emissivity sliding glass doors

Stainless steel reinforced threshold

MODEL FEATURES

Low profile cabinet design

Electronic control, off cycle defrost

LED interior lighting

Easily accessible and serviceable slide-out condensing unit

¹ R-290 refrigerant meets all federal and state regulatory requirements.

APPROVAL:

Model Specifications

DIMENSIONAL DATA

Net Capacity (cubic feet)	16 (453 cu l)
Width, Overall (inches)	50 (1270 mm)
Depth, Overall (inches) (including top)	29 (737 mm)
Depth, Body Only (inches) (less doors)	25 (635 mm)
Height, Overall (inches)	34 3/4 (883 mm)
Bottle/Can capacity (12oz)	61 (per shelf)
Number of Doors	4
Number of Shelves	4

REFRIGERANT DATA

Condensing Unit Size (H.P.)	1/4
Capacity (BTU per hour)*	1800

ELECTRICAL DATA

Voltage (International)	115/60/1 (220/50/1)
Feed Wires (including ground)	3
Total Amps (International)	3.7 (3.4)
10 ft. Cord/Plug [attached] (International)	Yes (No)

SHIPPING DATA

Weight (pounds)	370 (168 kg)
Height - Crated (inches)	46 (1168 mm)
Width - Crated (inches)	58 (1473 mm)
Depth - Crated (inches)	42 (1067 mm)

* Rating @ +25°F evaporator, 90°F ambient
Figures in parentheses reflect metric equivalents rounded to the nearest whole unit.



Equipped with one NEMA-5-15P Plug
(varies by country)

Continental
Refrigerator

Toll-Free: 800-523-7138
Phone: 215-244-1400
Fax: 215-244-9579

539 Dunksferry Road
Bensalem, PA 19020
www.continentalrefrigerator.com

Due to our continued efforts in developing innovative products, specifications subject to change without notice.



PROUDLY
DESIGNED & ASSEMBLED
IN THE U.S.A.

© Copyright 2021. Continental Refrigerator.
A Division of National Refrigeration & Air Conditioning Products, Inc.

Model Plan Views

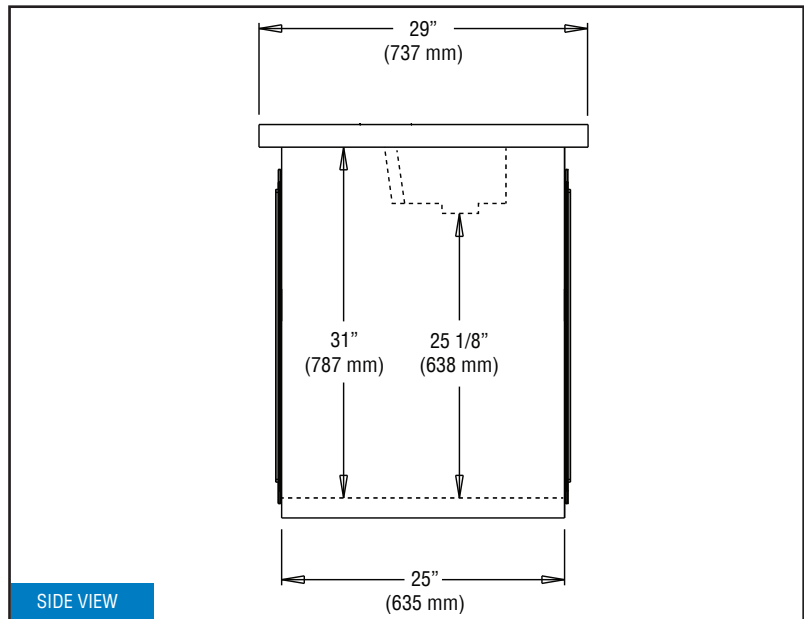
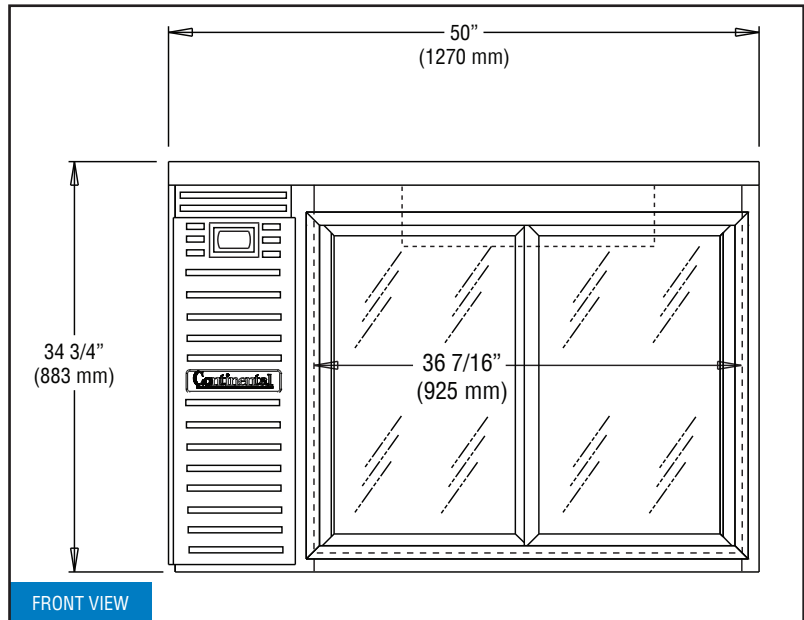

REVISED: 5/10/24