

# GRIDDLE STAND REFRIGERATOR

## Model: D108GN

Natural Refrigerant R-290 Model

## 108" Griddle Stand Refrigerator



ENERGY STAR® Qualified Commercial Refrigerator

Stainless steel exterior and interior, reinforced stainless steel work top with drip guard marine edge and stainless steel case back.



## Options and Accessories

(upcharge and lead times may apply)

Flat top in lieu of marine edge	Integral heat shield top
16 gauge stainless steel top (flat top only)	Cylinder locks
Condensing unit on left (standard on right)	Top extensions (flat or marine edge)
Special electrical requirements (consult factory)	

Consult factory for other model configurations, options and accessories.

**Continental**  
Refrigerator



Project Name:

Model Specified:

Location:

Item No:

Quantity:

AIA #:

SIS #:

## Standard Model Features

### REFRIGERATION SYSTEM

Performance rated refrigeration system

Natural, environmentally safe, high efficiency R-290 refrigerant<sup>1</sup>

Automatic, hot gas condensate evaporator

Non-corrosive, plasticized fin evaporator coil

Expansion valve system

Easily serviceable, front slide outcondensing unit

### CABINET ARCHITECTURE

High density, non-CFC polyurethane foamed-in-place insulation

Easy glide, fully extendable drawers designed to hold 6" deep pans side-by-side

Smooth, polished chrome drawer handles

One-piece, snap in magnetic Santoprene™ drawer gaskets

Heavy duty drawer track with built in drawer safety clips

Drawers designed to hold 250 lb. capacity

(6) drawer pan divider bars\*

4" casters on support plates

\* Pans supplied by others

### MODEL FEATURES

Electronic control, off-cycle defrost

Front breathing

<sup>1</sup> R-290 refrigerant meets all federal and state regulatory requirements.

APPROVAL:

## Model Specifications

### DIMENSIONAL DATA

Net Capacity (cubic feet)	27.4 (776 cu l)
Width, Overall (inches)	108 (2743 mm)
Depth, Overall (inches) (including handles)	35 (897 mm)
Height, Overall (inches) (including 4" casters)	26 (670 mm)
Number of Drawers	6

### REFRIGERANT DATA

Condensing Unit Size (H.P.)	1/4+
Capacity (BTU per hour)*	3100

### ELECTRICAL DATA

Voltage (International)	115/60/1 (220/50/1)
Feed Wires (including ground)	3
Total Amps (International)	4.5 (3.4)
10 ft. Cord/Plug [attached] (International)	Yes (No)

### SHIPPING DATA

Weight (pounds)	760 (345 kg)
Height - Crated (inches)	30 (762 mm)
Width - Crated (inches)	116 (3175 mm)
Depth - Crated (inches)	40 3/4 (991 mm)

### DRAWER PAN DIVIDERS (supplied with model)

CM2-0862	6 (one per drawer)
----------	--------------------

See drawer pan configurations on right (**pans not supplied**). For other drawer pan configurations, consult factory.

### TOP WEIGHT CAPACITY

Max. Top Weight Capacity (pounds)	1400 (635 kg)
-----------------------------------	---------------

\* Rating @ +25°F evaporator, 90°F ambient  
Figures in parentheses reflect metric equivalents rounded to the nearest whole unit.



Equipped with one NEMA-5-15P Plug  
(varies by country)

**Continental**  
Refrigerator

Toll-Free: 800-523-7138  
Phone: 215-244-1400  
Fax: 215-244-9579

539 Dunksferry Road  
Bensalem, PA 19020  
[www.continentalrefrigerator.com](http://www.continentalrefrigerator.com)

Due to our continued efforts in developing innovative products, specifications subject to change without notice.



PROUDLY  
DESIGNED & ASSEMBLED  
IN THE U.S.A.

© Copyright 2021. Continental Refrigerator.  
A Division of National Refrigeration & Air Conditioning Products, Inc.

## Model Plan Views

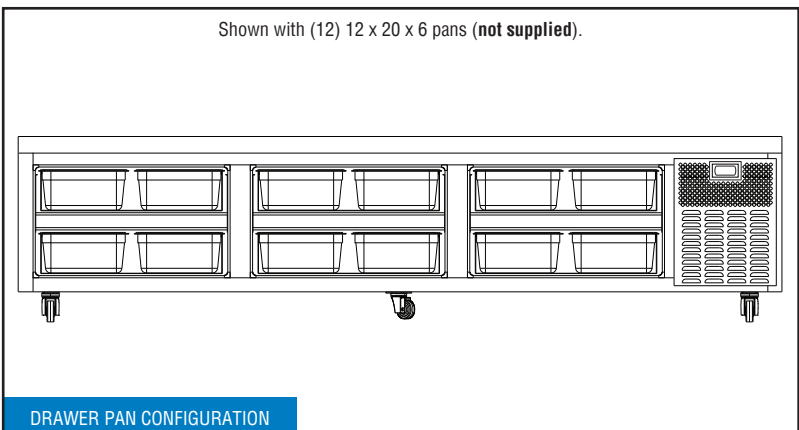
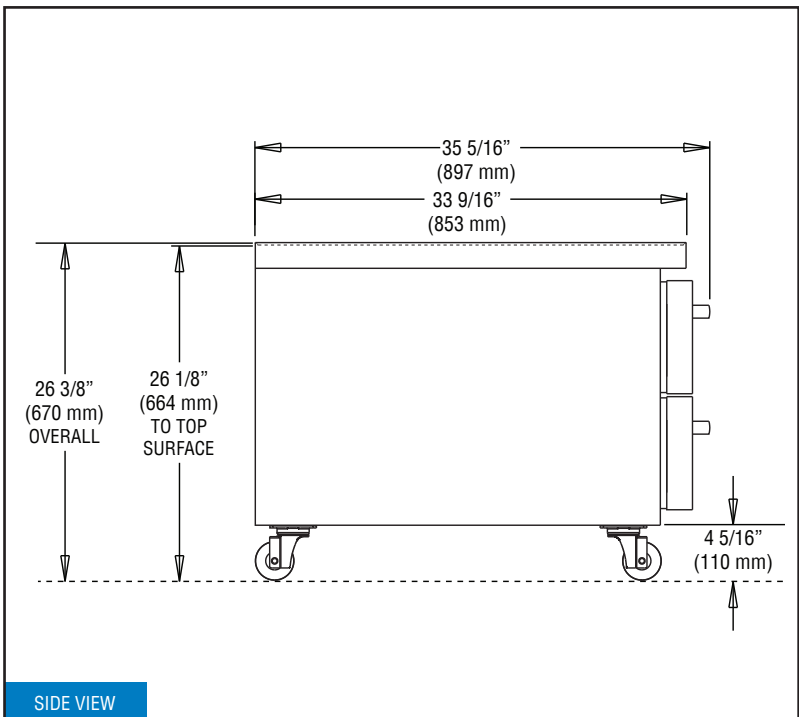
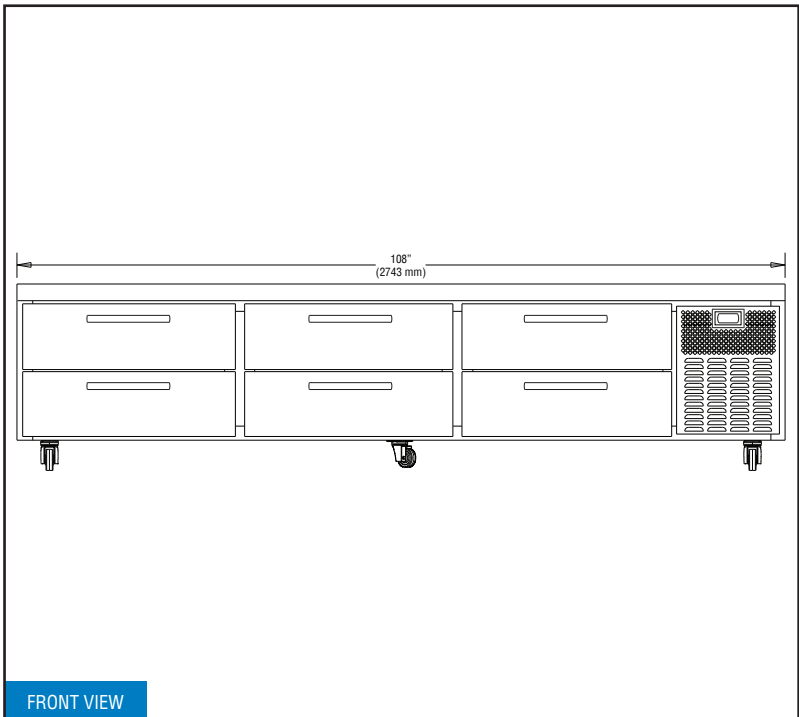

REVISED: 2/8/24