

DESIGNER LINE REFRIGERATOR

Model: D1RXNPT

Natural Refrigerant R-290 Model

Designer Line

1-Section Extra-Wide Pass-Thru Refrigerator

D1RXNPT - Stainless steel front, aluminum end panels and interior

D1RXNSAPT - Stainless steel exterior, aluminum interior

D1RXNSSPT - Stainless steel exterior and interior



Options and Accessories

(upcharge and lead times may apply)

Additional epoxy coated steel shelves	Correctional Facility Options
Chrome or stainless steel shelves	• One way security screws
Wine racks	• Locking hasp (lock not included)
Caster options	• Stainless steel mesh cover
Custom laminates	• Coverless hinges
Re-hinging of doors (consult factory)	Special electrical requirements (consult factory)
Glass door(s) (consult factory)	

Consult factory for other model configurations, options and accessories.

Continental
Refrigerator



Project Name:

Model Specified:

Location:

Item No:

Quantity:

AIA #:

SIS #:

Standard Model Features

REFRIGERATION SYSTEM

Self contained, performance rated "plug" refrigeration system

Natural, environmentally safe, high efficiency R-290 refrigerant¹

Refrigeration system is readily accessible on top of cabinet, separate from the "food zone"

Automatic, hot gas condensate evaporator

Expansion valve system

CABINET ARCHITECTURE

3" non-CFC polyurethane foam insulation

Smooth, polished chrome workflow door handle

Cam action, lift off hinges

Self-closing door

Magnetic snap-in Santoprene™ door gasket

Cylinder lock in door

Heavy duty pilaster strips

Heavy duty, epoxy coated steel shelves

Adjustable 6" stainless steel legs

MODEL FEATURES

LED interior lighting

Electronic control, off cycle defrost

Top and side air distribution ducts

Cabinet upper side panels and refrigeration "plug" system can be removed and reinstalled at job site

¹ R-290 refrigerant meets all federal and state regulatory requirements.

APPROVAL:

Model Specifications

DIMENSIONAL DATA

Net Capacity (cubic feet)	32 (906 cu l)
Width, Overall (inches)	36 1/4 (921 mm)
Depth, Overall (inches) (including handles)	38 3/4 (984 mm)
Depth (inches) (less doors)	32 (813 mm)
Depth (inches) (doors open 90°)	79 (2007 mm)
Clear Door Width (inches)	29 5/8 (752 mm)
Clear Door Height (inches)	58 5/8 (1489 mm)
Height, Overall (inches) (including 6" legs)	83 1/4 (2115 mm)
Number of Doors	2
Number of Shelves	3
Shelf Area (square feet)	24.4 (2.3 sq m)

REFRIGERANT DATA

Condensing Unit Size (H.P.)	1/3+
Capacity (BTU per hour)*	2560

ELECTRICAL DATA

Voltage (International)	115/60/1 (220/50/1)
Feed Wires (including ground)	3
Total Amps (International)	6.4 (4.3)
10 ft. Cord/Plug [attached] (International)	Yes (No)

SHIPPING DATA

Height - Crated (inches)	85 1/2 (2172 mm)
Width - Crated (inches)	42 (1067 mm)
Depth - Crated (inches)	42 (1067 mm)
Volume - Crated (cubic feet)	87 (2464 cu l)
Weight Std - Crated (pounds)	415 (189 kg)
Weight SS - Crated (pounds)	495 (225 kg)

* Rating @ +25°F evaporator, 90°F ambient
Figures in parentheses reflect metric equivalents rounded to the nearest whole unit.



Equipped with one NEMA-5-15P Plug
(varies by country)

Continental®

Refrigerator

Toll-Free: 800-523-7138
Phone: 215-244-1400
Fax: 215-244-9579

539 Dunksferry Road
Bensalem, PA 19020
www.continentalrefrigerator.com

Due to our continued efforts in developing innovative products, specifications subject to change without notice.



PROUDLY
DESIGNED & ASSEMBLED
IN THE U.S.A.

© Copyright 2021. Continental Refrigerator.
A Division of National Refrigeration & Air Conditioning Products, Inc.

Model Plan Views

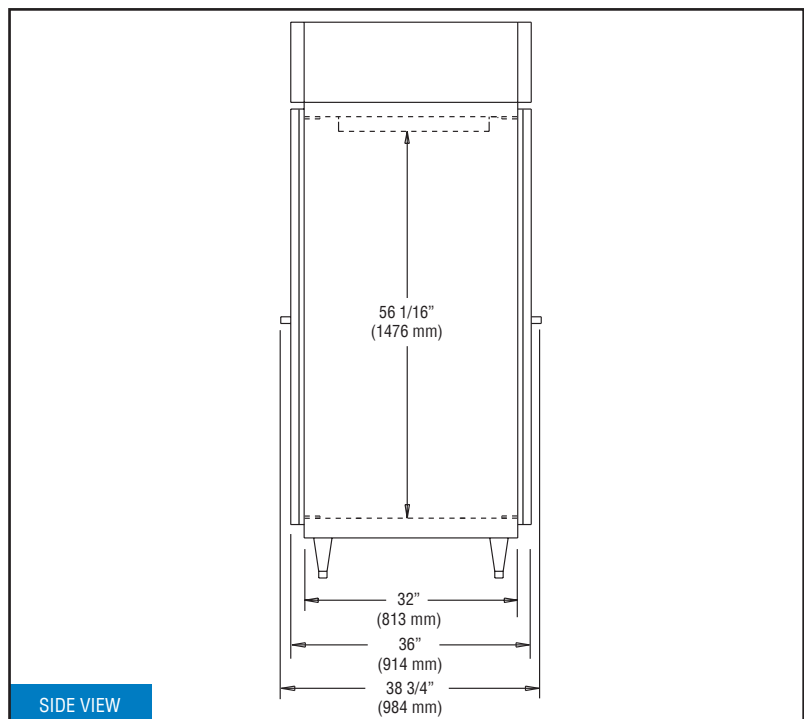
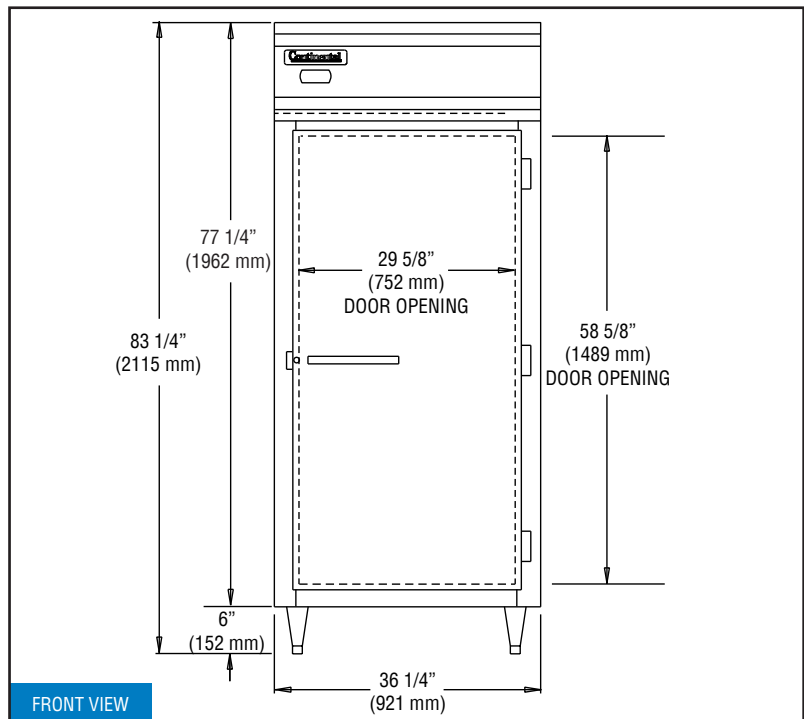

IMPORTANT NOTE: If the cabinet is located under a low ceiling, a minimum clearance of 12" is required on top and 3" on sides.

REVISED: 6/27/24