

DESIGNER LINE SANDWICH UNIT

Model: D60N12C-FB-D

Natural Refrigerant R-290 Model



60" Cutting Top Sandwich Unit Refrigerator with Drawers - 12 Pans Front Breathing

Stainless steel front, top and end panels and interior.



Options and Accessories

(upcharge and lead times may apply)

| | |
|--------------------------------|----------------------------|
| Stainless steel back | Rear mounted cutting board |
| Overshelves (single or double) | Composite cutting board |
| Drawer locks | Flat insulated night cover |
| Modified pan openings | Vision panel lid |

Consult factory for other model configurations, options and accessories.



Project Name:

Model Specified:

Location:

Item No:

Quantity:

AIA #:

SIS #:

Standard Model Features

REFRIGERATION SYSTEM

Performance rated refrigeration system

Natural, environmentally safe, high efficiency R-290 refrigerant¹

Unique air flow distribution allows pan product to maintain 33° - 41°F

Automatic, hot gas condensate evaporator

Non-corrosive, plasticized fin evaporator coil

Expansion valve system

Easily serviceable, back mounted compressor

CABINET ARCHITECTURE

2" non-CFC polyurethane foam insulation

Smooth, polished chrome door handles

Stainless steel roll out drawers

Magnetic snap in Santoprene™ door gaskets

19" deep, full length nylon cutting board

Insulated lid

Completely enclosed, vented and removable case back

3 3/4" Casters

MODEL FEATURES

Electronic control, off cycle defrost

(12) 1/6 size recessed pans, 4" deep

Removable interior tub below pans

¹ R-290 refrigerant meets all federal and state regulatory requirements.

APPROVAL:

Model Specifications

DIMENSIONAL DATA

| | |
|--|-----------------|
| Net Capacity (cubic feet) | 17.0 (481 cu l) |
| 1/6 Size Pans (4" deep) | 12 |
| Width, Overall (inches) | 60 (1524 mm) |
| Depth, Overall (inches) (including cutting board & bumpers) | 38 1/4 (972 mm) |
| Depth, Cutting Board (inches) | 19 (483 mm) |
| Height, Overall (inches) (including 3 3/4" casters) | 41 (1041 mm) |
| Number of Drawers | 4 |

REFRIGERANT DATA

| | |
|-----------------------------|------|
| Condensing Unit Size (H.P.) | 1/3+ |
| Capacity (BTU per hour)* | 2560 |

ELECTRICAL DATA

| | |
|--|---------------------|
| Voltage (International) | 115/60/1 (220/50/1) |
| Total Amps (International) | 5.7 (3.6) |
| 10 ft. Cord/Plug [attached] (International) | Yes (No) |

SHIPPING DATA

| | |
|--------------------------|------------------|
| Weight (pounds) | 475 (216 kg) |
| Height - Crated (inches) | 43 1/4 (1099 mm) |
| Width - Crated (inches) | 68 (1727 mm) |
| Depth - Crated (inches) | 37 1/4 (946 mm) |

DRAWER PAN CONFIGURATIONS

Two Tier: (1) 12 x 20 x 6 pan per drawer

* Rating @ +25°F evaporator, 90°F ambient
Figures in parentheses reflect metric equivalents rounded to the nearest whole unit.



Equipped with one NEMA-5-15P Plug
(varies by country)

Continental[®]

Refrigerator

Toll-Free: 800-523-7138
Phone: 215-244-1400
Fax: 215-244-9579

539 Dunksferry Road
Bensalem, PA 19020
www.continentalrefrigerator.com

Due to our continued efforts in developing innovative products, specifications subject to change without notice.



PROUDLY
DESIGNED & ASSEMBLED
IN THE U.S.A.

© Copyright 2021. Continental Refrigerator.
A Division of National Refrigeration & Air Conditioning Products, Inc.

Model Plan Views

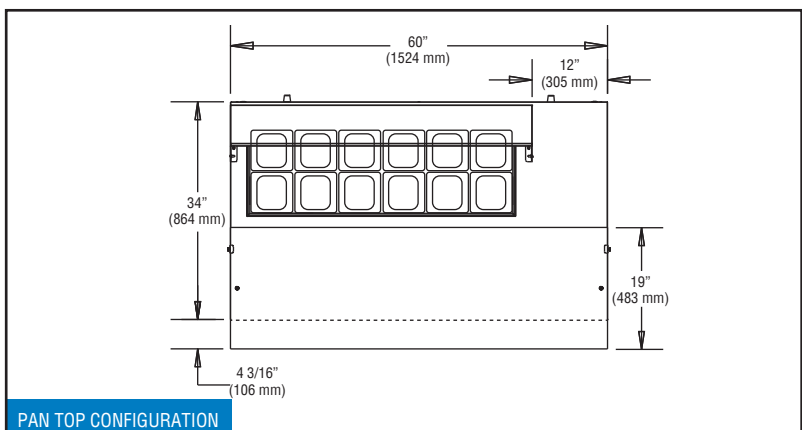
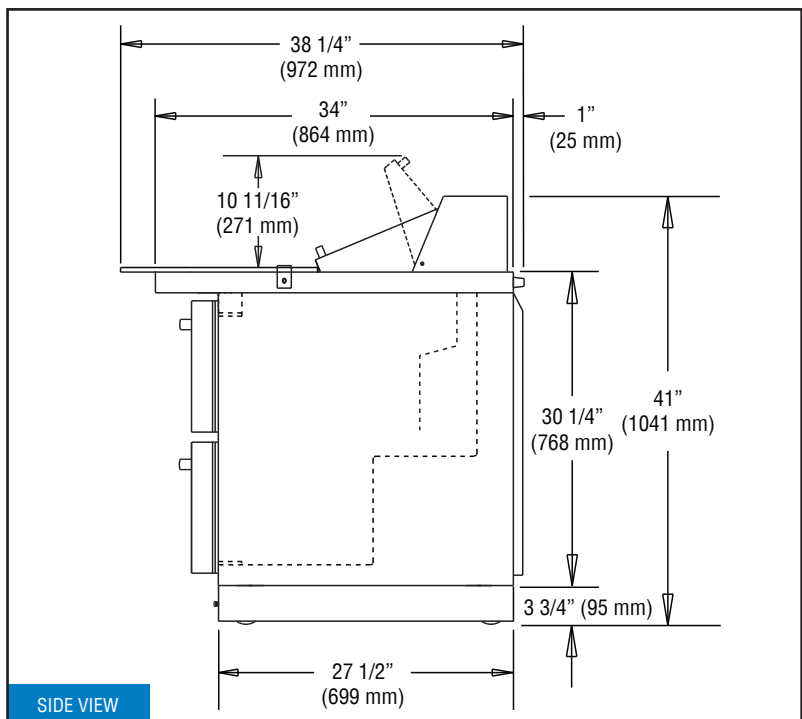
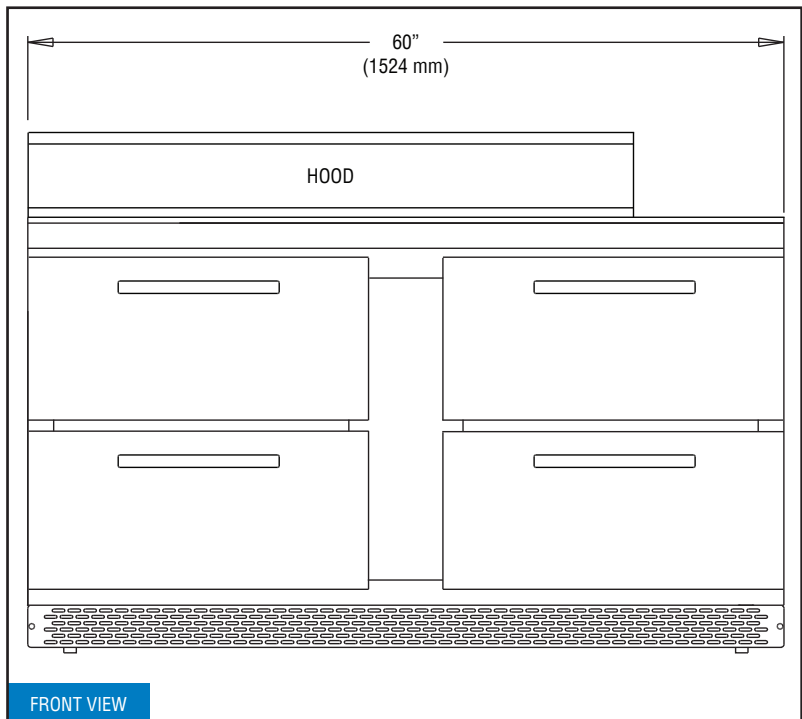

REVISED: 6/8/2024