

# DESIGNER LINE SANDWICH UNIT

**Model: D72N18M-FB-D**

Natural Refrigerant R-290 Model



72" Mighty Top Sandwich Unit  
Refrigerator with Drawers - 18 Pans  
Front Breathing

Stainless steel front, top and end panels and interior.



## Options and Accessories

(upcharge and lead times may apply)

|                                |                            |
|--------------------------------|----------------------------|
| Stainless steel back           | Rear mounted cutting board |
| Overshelves (single or double) | Composite cutting board    |
| Drawer locks                   | Flat insulated night cover |
| Crumb catcher                  | Vision panel lid           |
|                                | Modified pan openings      |

Consult factory for other model configurations, options and accessories.

Project Name:

Model Specified:

Location:

Item No:

Quantity:

AIA #:

SIS #:

## Standard Model Features

### REFRIGERATION SYSTEM

Performance rated refrigeration system

Natural, environmentally safe,  
high efficiency R-290 refrigerant<sup>1</sup>

Unique air flow distribution allows  
pan product to maintain 33° - 41°F

Automatic, hot gas condensate evaporator

Non-corrosive, plasticized fin evaporator coil

Expansion valve system

Easily serviceable, back mounted compressor

### CABINET ARCHITECTURE

2" non-CFC polyurethane foam insulation

Smooth, polished chrome door handles

Stainless steel roll out drawers

Magnetic snap in Santoprene™ door gaskets

8" deep, full length nylon cutting board

Insulated lid

Completely enclosed, vented and removable case back

3 3/4" Casters

### MODEL FEATURES

Electronic control, off cycle defrost

(18) 1/6 size recessed pans, 4" deep

Removable interior tub below pans

<sup>1</sup> R-290 refrigerant meets all federal and state regulatory requirements.

**Continental**<sup>®</sup>  
Refrigerator



APPROVAL:

# Model Specifications

## DIMENSIONAL DATA

|  |                 |
|--|-----------------|
| Net Capacity (cubic feet)                              | 20.6 (583 cu l) |
| 1/6 Size Pans (4" deep)                                | 18              |
| Width, Overall (inches)                                | 72 (1829 mm)    |
| Depth, Overall (inches)<br>(including bumpers)         | 35 (890 mm)     |
| Depth, Cutting Board (inches)                          | 8 (203 mm)      |
| Height, Overall (inches)<br>(including 3 3/4" casters) | 41 (1041 mm)    |
| Number of Drawers                                      | 6               |

## REFRIGERANT DATA

|                             |      |
|-----------------------------|------|
| Condensing Unit Size (H.P.) | 1/3+ |
| Capacity (BTU per hour)*    | 2560 |

## ELECTRICAL DATA

|  |                     |
|--|---------------------|
| Voltage (International)                        | 115/60/1 (220/50/1) |
| Total Amps (International)                     | 6.0 (3.6)           |
| 10 ft. Cord/Plug [attached]<br>(International) | Yes<br>(No)         |

## SHIPPING DATA

|                          |                  |
|--------------------------|------------------|
| Weight (pounds)          | 565 (257 kg)     |
| Height - Crated (inches) | 43 1/4 (1099 mm) |
| Width - Crated (inches)  | 80 (2032 mm)     |
| Depth - Crated (inches)  | 37 1/4 (946 mm)  |

## DRAWER PAN CONFIGURATIONS

**Two Tier:** (1) 1/2 size x 6 & (1) 1/3 x 6 pan per drawer

\* Rating @ +25°F evaporator, 90°F ambient  
Figures in parentheses reflect metric equivalents rounded to the nearest whole unit.



Equipped with one NEMA-5-15P Plug  
(varies by country)

# Continental<sup>®</sup>

Refrigerator

Toll-Free: 800-523-7138  
Phone: 215-244-1400  
Fax: 215-244-9579

539 Dunksferry Road  
Bensalem, PA 19020  
[www.continentalrefrigerator.com](http://www.continentalrefrigerator.com)

Due to our continued efforts in developing innovative products, specifications subject to change without notice.



PROUDLY  
DESIGNED & ASSEMBLED  
IN THE U.S.A.

Intertek

© Copyright 2021. Continental Refrigerator.  
A Division of National Refrigeration & Air Conditioning Products, Inc.

# Model Plan Views

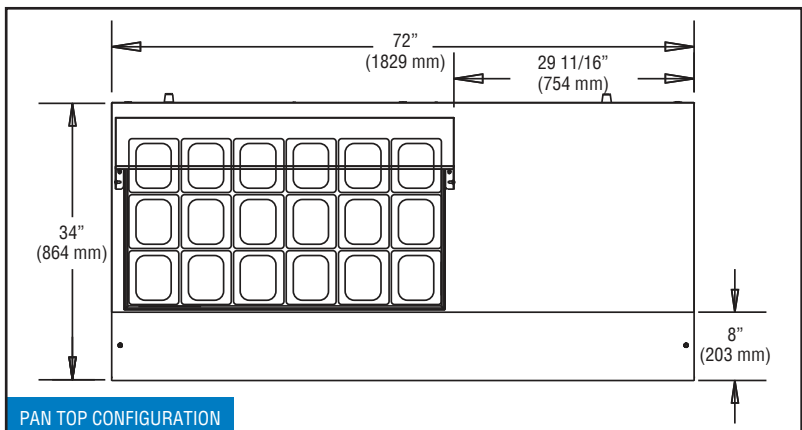
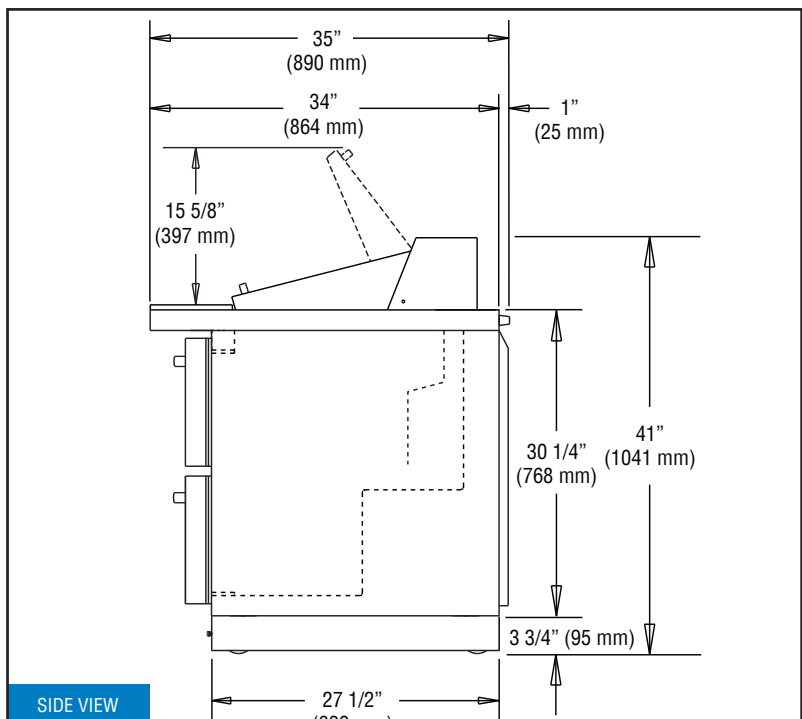
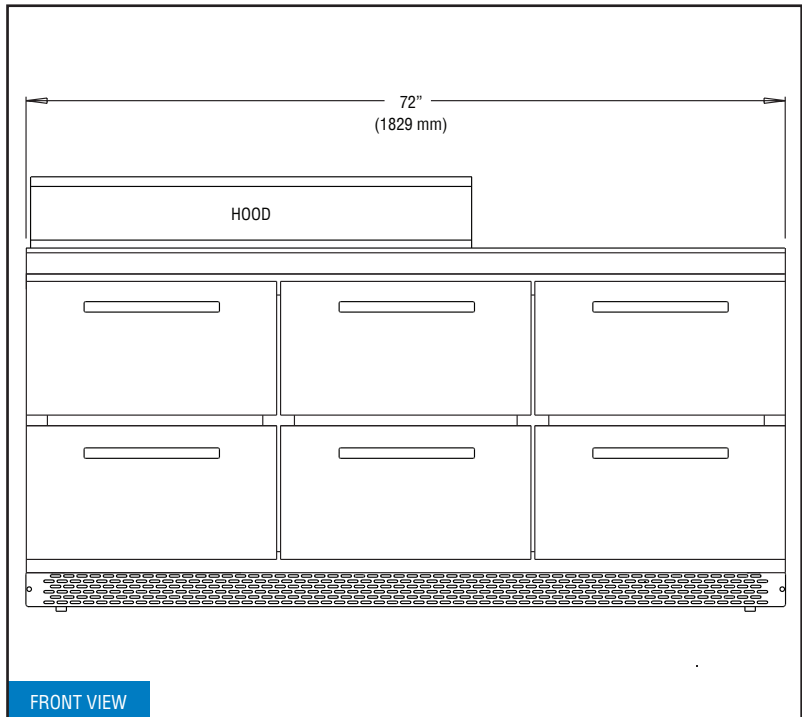

REVISED: 6/8/2024