

DESIGNER LINE BASE MODEL

Model: DFA68NSS-D

Natural Refrigerant R-290 Model



68" Base Worktop Freezer with Drawers

Heavy gauge #300 Series stainless steel top, stainless steel front, end panels and interior, galvanized steel rear and grill.



Options and Accessories

(upcharge and lead times may apply)

Stainless steel back	Different size casters
Overshelves (single or double)	Door locks
Drawer in lieu of door section above the condensing unit*	Front breathing
	Compressor left (standard on right)

Consult factory for other model configurations, options and accessories.

*Drawer section above condensing unit holds (1) 12 x 20 x 6 pan.



Project Name:

Model Specified:

Location:

Item No:

Quantity:

AIA #:

SIS #:

Standard Model Features

REFRIGERATION SYSTEM

Performance rated refrigeration system

Natural, environmentally safe, high efficiency R-290 refrigerant¹

Unique forced air design utilizes fans (approx. every 12") across the entire back of unit for even distribution of cold

Automatic, hot gas condensate evaporator

Non-corrosive, plasticized fin evaporator coil

Easily serviceable, slide-out condensing unit

Expansion valve system

CABINET ARCHITECTURE

2" non-CFC polyurethane foam insulation

Smooth, polished chrome drawer/door handles

Spring loaded, self closing door (over condensing unit)

Magnetic, snap in Santoprene™ door & drawer gaskets

Stainless steel roll out drawers

Completely enclosed, vented and removable rear and side grills

6" adjustable stainless steel legs

MODEL FEATURES

Electronic control, automatic electric defrost

Refrigerated section with door above the condensing unit

Field rehingeable door (over condensing unit)

¹ R-290 refrigerant meets all federal and state regulatory requirements.

NOTE: Models come standard with a door over the condensing unit. A drawer over the condensing unit is an option.

APPROVAL:

Model Specifications

DIMENSIONAL DATA

Net Capacity (cubic feet)	22 (623 cu l)
Width, Overall (inches)	68 (1727 mm)
Depth, Overall (inches) (including handles & bumpers)	36 5/16 (922 mm)
Height, Overall (inches) (including 6" legs)	41 1/2 (1054 mm)
Number of Drawers	4
Number of Half Doors	1
Interior Depth (inches) (above condenser)	30 (762 mm)
Interior Height (inches) (above condenser)	12 1/2 (318 mm)
Interior Width (inches) (above condenser)	17 (432 mm)

REFRIGERANT DATA

Condensing Unit Size (H.P.)	1/2
Capacity (BTU per hour)*	2310

ELECTRICAL DATA

Voltage (International)	115/60/1 (220/50/1)
Total Amps (International)	7.0 (4.2)
Defrost Amps (International)	9.1 (4.8)
10 ft. Cord/Plug [attached] (International)	Yes (No)

SHIPPING DATA

Weight (pounds)	540 (245 kg)
Height - Crated (inches)	43 3/4 (1111 mm)
Width - Crated (inches)	70 (1778 mm)
Depth - Crated (inches)	47 (1194 mm)

DRAWER PAN CONFIGURATIONS

Two Tier: (2) 12 x 20 x 6 pans per drawer

* Rating @ +25°F evaporator, 90°F ambient
Figures in parentheses reflect metric equivalents rounded to the nearest whole unit.



Equipped with one NEMA-5-15P Plug
(varies by country)

Model Plan Views

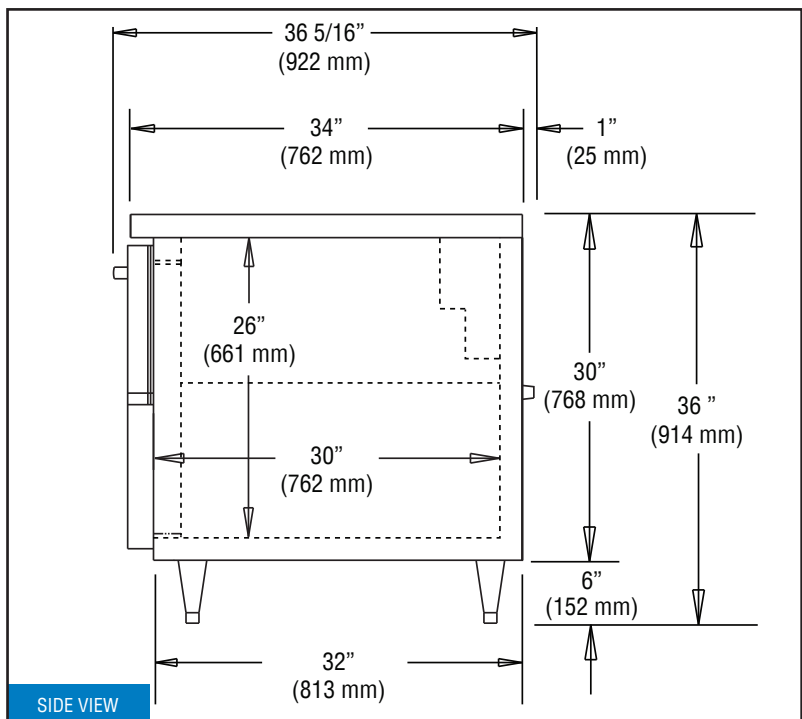
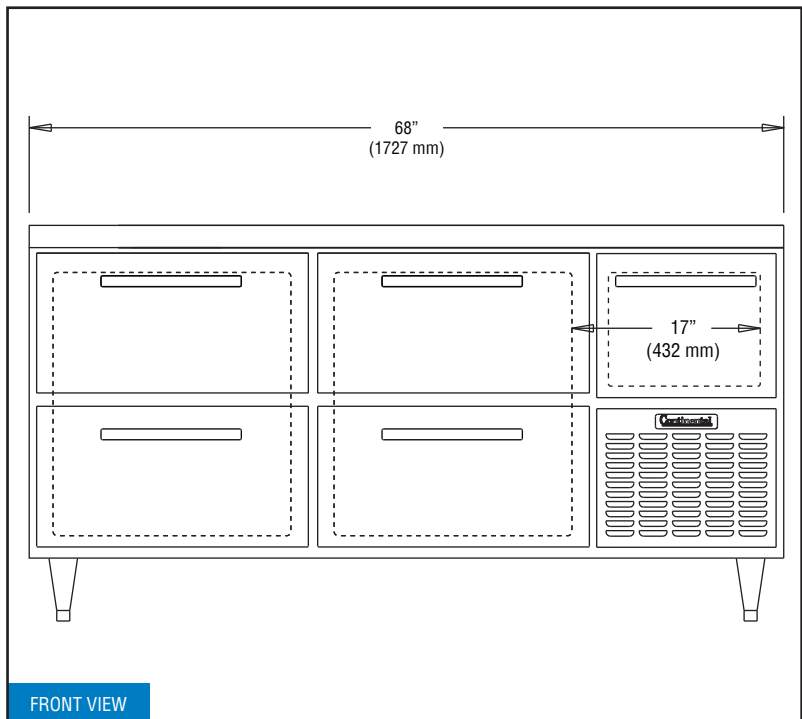

IMPORTANT NOTE: If the cabinet is located directly against a wall, a minimum clearance of 3" is required on sides, front and rear.

Continental
Refrigerator

Toll-Free: 800-523-7138
Phone: 215-244-1400
Fax: 215-244-9579

539 Dunksferry Road
Bensalem, PA 19020
www.continentalrefrigerator.com

Due to our continued efforts in developing innovative products, specifications subject to change without notice.



PROUDLY
DESIGNED & ASSEMBLED
IN THE U.S.A.

Intertek

© Copyright 2021. Continental Refrigerator.
A Division of National Refrigeration & Air Conditioning Products, Inc.

REVISED: 5/02/2024