

PIZZA PREPARATION TABLE

Model: PA93N

Natural Refrigerant R-290 Model

93" Pizza Preparation Refrigerator with Solid Doors

Heavy gauge #300 series stainless steel top, stainless steel front and end panels, aluminum interior.



Options and Accessories

(upcharge and lead times may apply)

Stainless steel interior	Pan slides
Stainless steel back	Wire rod garnish rack
Overshelves (single or double)	Vision panel lid
Additional epoxy coated steel shelves	Door locks
Stainless steel shelves	Adjustable legs
Condensing unit on left (standard on right)	Front breathing
Drawer in lieu of half door above condensing unit*	Special electrical requirements (consult factory)
Drawers in lieu of doors (consult factory)**	

Consult factory for other model configurations, options and accessories.

*Drawer section above condensing unit holds (1) 12 x 20 x 6 pan.

**Two tier (larger section): (2) 12x20x6 pans per drawer

Continental
Refrigerator



Project Name:

Model Specified:

Location:

Item No:

Quantity:

AIA #:

SIS #:

Standard Model Features

REFRIGERATION SYSTEM

Performance rated refrigeration system

Natural, environmentally safe, high efficiency R-290 refrigerant¹

Unique forced air design utilizes fans (approx. every 12") across the entire back of unit for even distribution of cold

Automatic, hot gas condensate evaporator

Non-corrosive, plasticized fin evaporator coil

Easily serviceable, slide out condensing unit

Expansion valve system

CABINET ARCHITECTURE

2" non-CFC polyurethane foam insulation

Smooth, polished chrome door handles

Spring loaded, self closing doors

Magnetic snap in Santoprene™ door gaskets

Heavy duty, epoxy coated steel shelves

19" deep, full length nylon cutting board

Insulated lids (with heavy duty hinge pins)

(10) pan top divider bars*

5" casters

* Pans supplied by others

MODEL FEATURES

Reversing condenser fan²

Ergonomically-friendly raised angle rail

Electronic control, off-cycle defrost

Refrigerated section with door above the condensing unit

Field rehingeable doors

¹ R-290 refrigerant meets all federal and state regulatory requirements.

² Fan runs in reverse for short period on startup to blow away any debris.

NOTE: Models come standard with a door above the condensing unit. A drawer above the condensing unit is an option.

APPROVAL:

Model Specifications

DIMENSIONAL DATA

Net Capacity (cubic feet)	32 (906 cu l)
Width, Overall (inches)	93 (2362 mm)
Depth, Overall (inches) (including cutting board & bumpers)	38 3/4 (972 mm)
Height, Overall (inches) (including 5" casters)	39 (989 mm)
Depth, Cutting Board (inches)	19 (483 mm)
Shelf Area (square feet)	14.2 (1.3 sq m)
Number of Shelves	3
Number of Full Doors	3
Number of Half Doors	1
Interior Depth (inches)	27 3/8 (695 mm)
Interior Height (inches)	26 (660 mm)
Interior Height (inches) (above condenser)	12 1/2 (318 mm)

PAN TOP

Divider Bars (supplied with model)	(10) CM1-0111
Pan Capacity (pans supplied by others)	(12) 1/3

REFRIGERANT DATA

Condensing Unit Size (H.P.)	1/2
Capacity (BTU per hour)*	5260

ELECTRICAL DATA

Voltage (International)	115/60/1 (220/50/1)
Total Amps (International)	9.0 (6.9)
10 ft. Cord/Plug [attached] (International)	Yes (No)

SHIPPING DATA

Weight (pounds)	622 (282 kg)
Height - Crated (inches)	43 3/4 (1111 mm)
Width - Crated (inches)	95 (2413 mm)
Depth - Crated (inches)	47 (1194 mm)

* Rating @ +25°F evaporator, 90°F ambient
Figures in parentheses reflect metric equivalents rounded to the nearest whole unit.



Equipped with one NEMA-5-15P Plug
(varies by country)

Model Plan Views

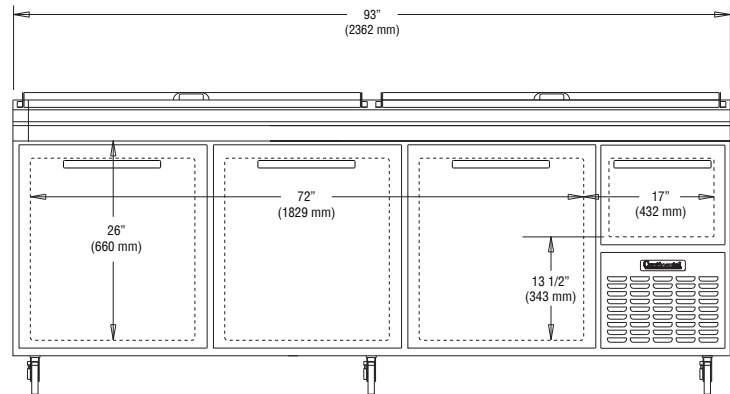

FRONT VIEW

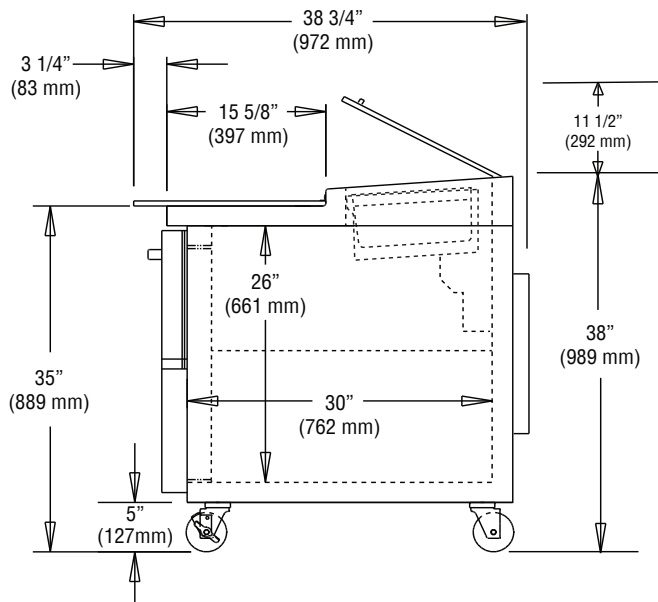

SIDE VIEW

IMPORTANT NOTE: If the cabinet is located directly against a wall, a minimum clearance of 3" is required on sides, front and rear.

Continental
Refrigerator

Toll-Free: 800-523-7138
Phone: 215-244-1400
Fax: 215-244-9579

539 Dunksferry Road
Bensalem, PA 19020
www.continentalrefrigerator.com

Due to our continued efforts in developing innovative products, specifications subject to change without notice.



PROUDLY
DESIGNED & ASSEMBLED
IN THE U.S.A.

Intertek

© Copyright 2021. Continental Refrigerator.
A Division of National Refrigeration & Air Conditioning Products, Inc.

REVISED: 1/29/24