

# BASE MODEL REFRIGERATOR

## Model: RA68N-D

Natural Refrigerant R-290 Model

### 68" Base Worktop Refrigerator with Drawers

Heavy gauge #300 Series stainless steel top, stainless steel front and end panels, galvanized steel rear and grill and aluminum interior.



## Options and Accessories

(upcharge and lead times may apply)

Stainless steel interior	Different size casters
Stainless steel back	Adjustable legs
Overshelves (single or double)	Door locks
Drawer in lieu of door section above the condensing unit*	Front breathing
	Compressor left (standard on right)

Consult factory for other model configurations, options and accessories.

\*Drawer section above condensing unit holds (1) 12 x 20 x 6 pan.

**Continental**  
Refrigerator



Project Name:

Model Specified:

Location:

Item No:

Quantity:

AIA #:

SIS #:

## Standard Model Features

### REFRIGERATION SYSTEM

Performance rated refrigeration system

Natural, environmentally safe, high efficiency R-290 refrigerant<sup>1</sup>

Unique forced air design utilizes fans (approx. every 12") across the entire back of unit for even distribution of cold

Automatic, hot gas condensate evaporator

Non-corrosive, plasticized fin evaporator coil

Easily serviceable, slide out condensing unit

Expansion valve system

### CABINET ARCHITECTURE

2" non-CFC polyurethane foam insulation

Smooth, polished chrome door & drawer handles

Spring loaded, self closing door over condensing unit

Magnetic snap in Santoprene™ door & drawer gaskets

Stainless steel roll out drawers

Completely enclosed, vented and removable rear and side grills

5" casters

### MODEL FEATURES

Electronic control, off cycle defrost

Refrigerated section with door above the condensing unit

Field rehingeable door over condensing unit

<sup>1</sup> R-290 refrigerant meets all federal and state regulatory requirements.

**NOTE:** Models come standard with a door over the condensing unit. A drawer over the condensing unit is an option.

APPROVAL:

# Model Specifications

## DIMENSIONAL DATA

Net Capacity (cubic feet)	22 (623 cu l)
Width, Overall (inches)	68 (1727 mm)
Depth, Overall (inches) (including handles & bumpers)	36 9/16 (932 mm)
Height, Overall (inches) (including 5" casters)	35 (889 mm)
Number of Drawers	4
Number of Half Doors	1
Interior Depth (inches) (above condenser)	30 (762 mm)
Interior Height (inches) (above condenser)	12 1/2 (318 mm)
Interior Width (inches) (above condenser)	17 (432 mm)

## REFRIGERANT DATA

Condensing Unit Size (H.P.)	1/4+
Capacity (BTU per hour)*	4220

## ELECTRICAL DATA

Voltage (International)	115/60/1 (220/50/1)
Total Amps (International)	4.8 (3.3)
10 ft. Cord/Plug [attached] (International)	Yes (No)

## SHIPPING DATA

Weight (pounds)	520 (236 kg)
Height - Crated (inches)	43 3/4 (1111 mm)
Width - Crated (inches)	70 (1778 mm)
Depth - Crated (inches)	47 (1194 mm)

## DRAWER PAN CONFIGURATIONS

**Two Tier:** (2) 12 x 20 x 6 pans per drawer

\* Rating @ +25°F evaporator, 90°F ambient  
Figures in parentheses reflect metric equivalents rounded to the nearest whole unit.



Equipped with one NEMA-5-15P Plug  
(varies by country)

# Model Plan Views

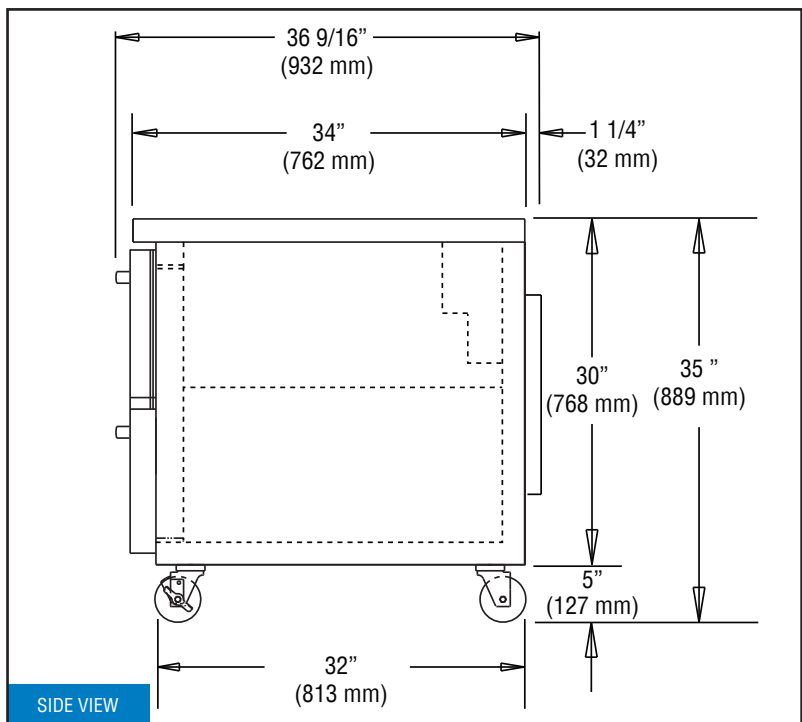
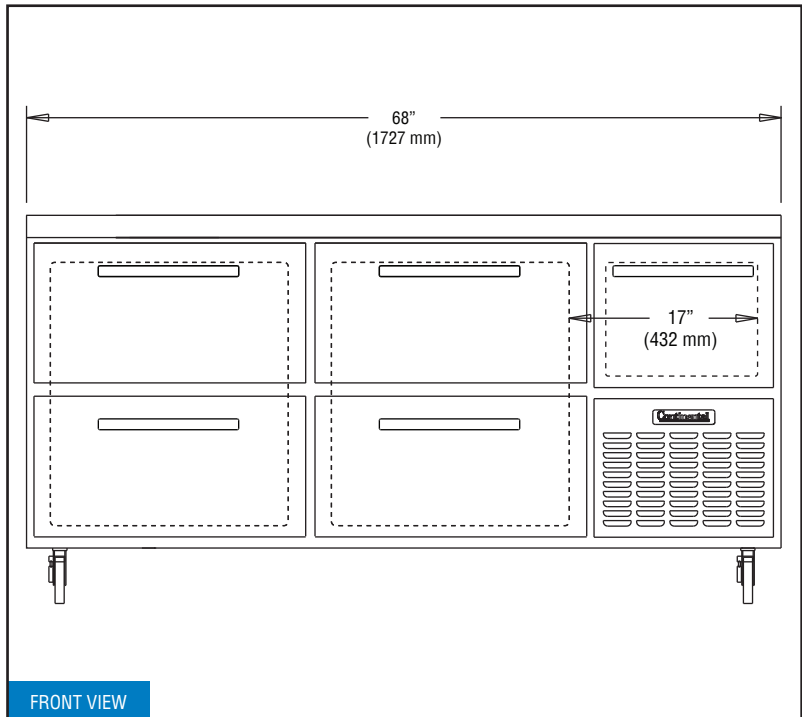

**IMPORTANT NOTE:** If the cabinet is located directly against a wall, a minimum clearance of 3" is required on sides, front and rear.

**Continental**  
Refrigerator

Toll-Free: 800-523-7138  
Phone: 215-244-1400  
Fax: 215-244-9579

539 Dunksferry Road  
Bensalem, PA 19020  
[www.continentalrefrigerator.com](http://www.continentalrefrigerator.com)

Due to our continued efforts in developing innovative products, specifications subject to change without notice.



PROUDLY  
DESIGNED & ASSEMBLED  
IN THE U.S.A.

**Intertek**

© Copyright 2021. Continental Refrigerator.  
A Division of National Refrigeration & Air Conditioning Products, Inc.

REVISED: 5/6/24