

WORKTOP REFRIGERATOR

Model: SW36N

Natural Refrigerant R-290 Model

36" Worktop Refrigerator with Solid Doors



ENERGY STAR® Qualified Commercial Refrigerator

Stainless steel front, top and end panels, aluminum back and interior.



Options and Accessories

(upcharge and lead times may apply)

| | |
|---------------------------------------|---|
| Stainless steel interior | Different caster sizes |
| Stainless steel back | Adjustable legs |
| Additional epoxy coated steel shelves | Door locks |
| Stainless steel shelves | Special electrical requirements (consult factory) |
| Overshelves (single or double) | |

Consult factory for other model configurations, options and accessories.

Continental
Refrigerator



Project Name:

Model Specified:

Location:

Item No:

Quantity:

AIA #:

SIS #:

Standard Model Features

REFRIGERATION SYSTEM

Performance rated refrigeration system

Natural, environmentally safe, high efficiency R-290 refrigerant¹

Automatic, hot gas condensate evaporator

Non-corrosive, plasticized fin evaporator coil

Easily serviceable, back mounted compressor

CABINET ARCHITECTURE

2" non-CFC polyurethane foam insulation

Smooth, polished chrome door handles

Spring loaded, self closing doors

Magnetic snap in Santoprene™ door gaskets

Heavy duty, epoxy coated steel shelves

Completely enclosed, vented and removable case back

5" casters

MODEL FEATURES

Field rehingeable doors

Electronic control, off-cycle defrost

¹ R-290 refrigerant meets all federal and state regulatory requirements.

APPROVAL:

Model Specifications

DIMENSIONAL DATA

| | |
|--|-----------------|
| Net Capacity (cubic feet) | 10.3 (292 cu l) |
| Width, Overall (inches) | 36 (914 mm) |
| Depth, Overall (inches) (including handles & bumpers) | 32 (818 mm) |
| Height, Overall (inches) (including 5" casters) | 35 (895 mm) |
| Shelf Area (square feet) | 4.6 (0.4 sq m) |
| Number of Shelves | 2 |
| Number of Doors | 2 |
| Interior Depth (inches) | See Drawing |
| Interior Height (inches) | 26 1/4 (667 mm) |
| Interior Width (inches) | 32 (813 mm) |

REFRIGERANT DATA

| | |
|-----------------------------|------|
| Condensing Unit Size (H.P.) | 1/5 |
| Capacity (BTU per hour)* | 1625 |

* Rating @ +25°F evaporator, 90°F ambient

ELECTRICAL DATA

| | |
|--|---------------------|
| Voltage (International) | 115/60/1 (220/50/1) |
| Total Amps (International) | 2.5 (2.2) |
| 10 ft. Cord/Plug [attached] (International) | Yes (No) |

SHIPPING DATA

| | |
|--------------------------|------------------|
| Weight (pounds) | 235 (107 kg) |
| Height - Crated (inches) | 43 1/4 (1099 mm) |
| Width - Crated (inches) | 44 (1118 mm) |
| Depth - Crated (inches) | 37 1/4 (946 mm) |

Figures in parentheses reflect metric equivalents rounded to the nearest whole unit.



Equipped with one NEMA-5-15P Plug
(varies by country)

Model Plan Views

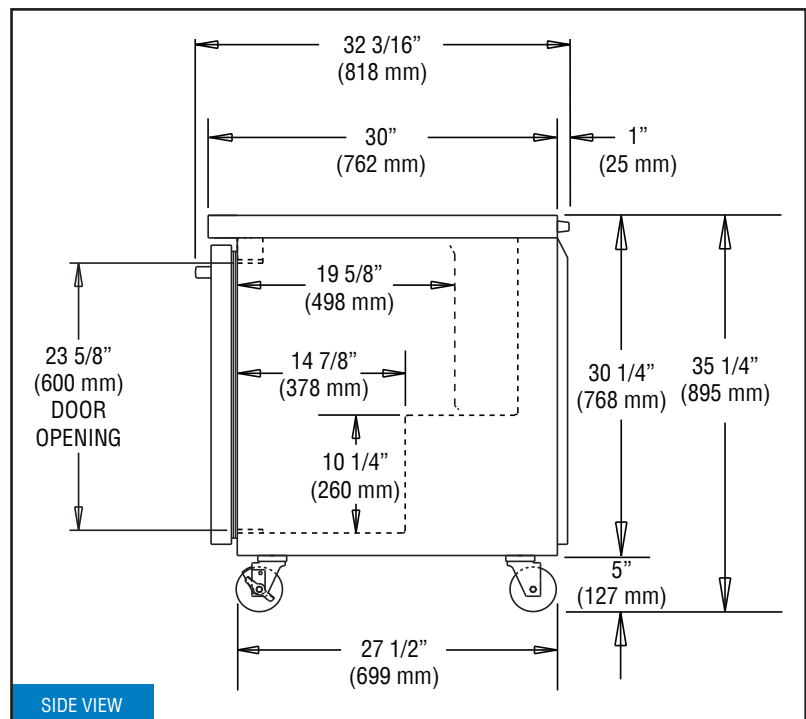
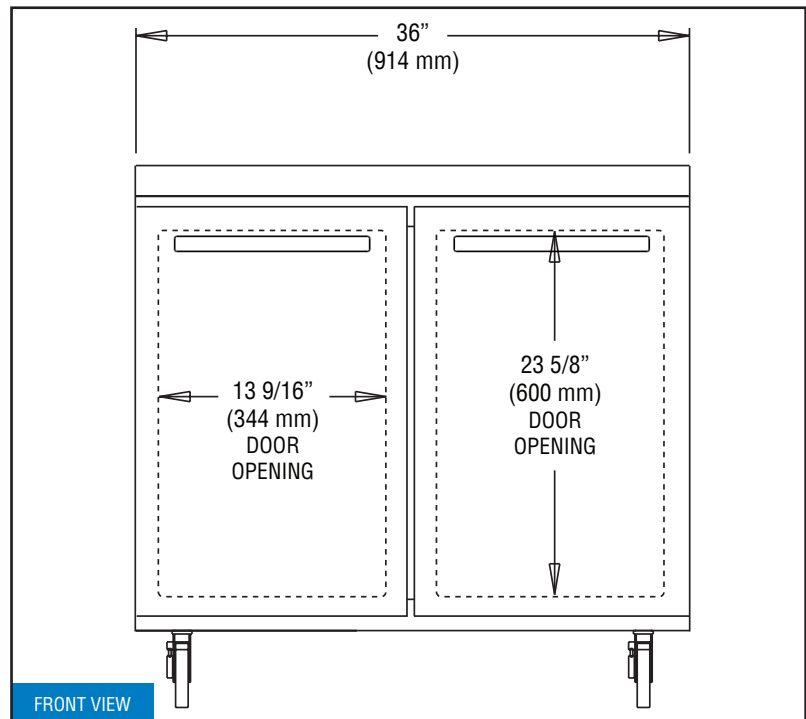

IMPORTANT NOTE: If the cabinet is located directly against a wall, a minimum clearance of 3" is required on sides, front and rear.

Continental
Refrigerator

Toll-Free: 800-523-7138
Phone: 215-244-1400
Fax: 215-244-9579

539 Dunksferry Road
Bensalem, PA 19020
www.continentalrefrigerator.com

Due to our continued efforts in developing innovative products, specifications subject to change without notice.



PROUDLY
DESIGNED & ASSEMBLED
IN THE U.S.A.

Intertek

© Copyright 2021. Continental Refrigerator.
A Division of National Refrigeration & Air Conditioning Products, Inc.

REVISED: 4/2/24