

WORKTOP FREEZER (0°F)

Model: SWF27NGD

Natural Refrigerant R-290 Model

27" Display Worktop Freezer with Hinged Glass Door

Stainless steel front, top and end panels, aluminum back and interior.



Options and Accessories

(upcharge and lead times may apply)

| | |
|---------------------------------------|--|
| Stainless steel interior | Different caster sizes |
| Stainless steel back | Adjustable legs |
| Additional epoxy coated steel shelves | Door lock |
| Stainless steel shelves | Special electrical requirements (consult factory) |
| Overshelves (single or double) | |

Consult factory for other model configurations, options and accessories.

Continental
Refrigerator



Project Name:

Model Specified:

Location:

Item No:

Quantity:

AIA #:

SIS #:

Standard Model Features

REFRIGERATION SYSTEM

Performance rated refrigeration system

Natural, environmentally safe,
high efficiency R-290 refrigerant¹

Automatic, hot gas condensate evaporator

Non-corrosive, plasticized fin evaporator coil

Easily serviceable, back mounted compressor

CABINET ARCHITECTURE

2" non-CFC polyurethane foam insulation

Double pane, low emissivity, tempered hinged glass door

Magnetic snap in door gasket

Heavy-duty, epoxy coated steel shelf

Completely enclosed, vented and removable case back

5" casters

MODEL FEATURES

LED interior lighting

Electronic control, automatic electric defrost

¹ R-290 refrigerant meets all federal and state regulatory requirements.

APPROVAL:

Model Specifications

DIMENSIONAL DATA

| | |
|---|------------------|
| Net Capacity (cubic feet) | 7.4 (210 cu l) |
| Width, Overall (inches) | 27 1/2 (699 mm) |
| Depth, Overall (inches) (including handle & bumpers) | 31 7/16 (799 mm) |
| Height, Overall (inches) (including 5" casters) | 35 1/4 (895 mm) |
| Shelf Area (square feet) | 3.5 (0.3 sq m) |
| Number of Shelves | 1 |
| Number of Doors | 1 |
| Interior Depth (inches) | See Drawing |
| Interior Height (inches) | 26 1/4 (667 mm) |
| Interior Width (inches) | 24 1/2 (622 mm) |

REFRIGERANT DATA

| | |
|-----------------------------|------|
| Condensing Unit Size (H.P.) | 1/4 |
| Capacity (BTU per hour)* | 1572 |

ELECTRICAL DATA

| | |
|--|---------------------|
| Voltage (International) | 115/60/1 (220/50/1) |
| Total Amps (International) | 4.0 (2.8) |
| Defrost Amps (International) | 4.8 (2.8) |
| 10 ft. Cord/Plug [attached] (International) | Yes (No) |

SHIPPING DATA

| | |
|--------------------------|------------------|
| Weight (pounds) | 206 (94 kg) |
| Height - Crated (inches) | 43 1/4 (1099 mm) |
| Width - Crated (inches) | 35 1/2 (902 mm) |
| Depth - Crated (inches) | 37 1/4 (946 mm) |

* Rating @ -15°F evaporator, 90°F ambient
Figures in parentheses reflect metric equivalents rounded to the nearest whole unit.



Equipped with one NEMA-5-15P Plug
(varies by country)

Model Plan Views

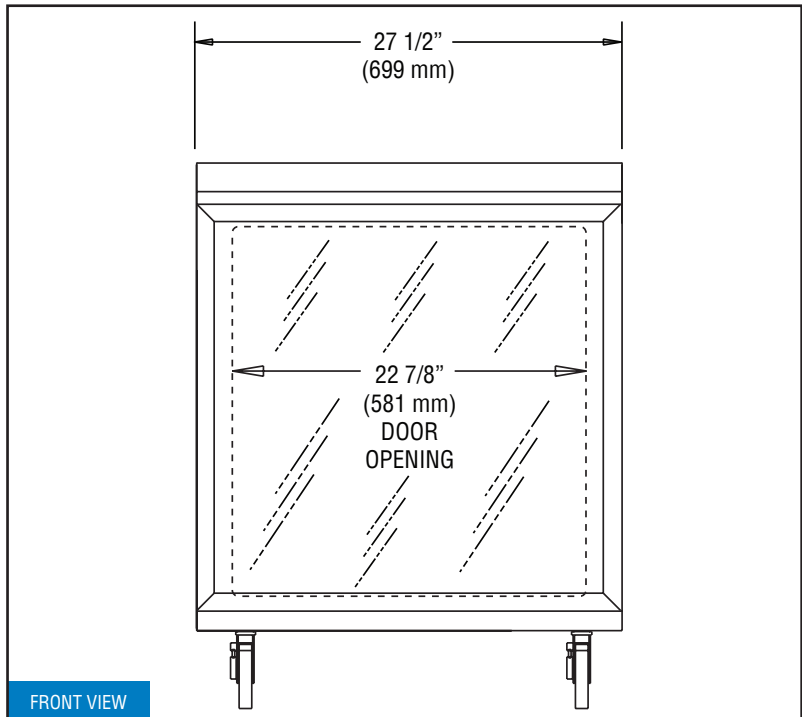

FRONT VIEW

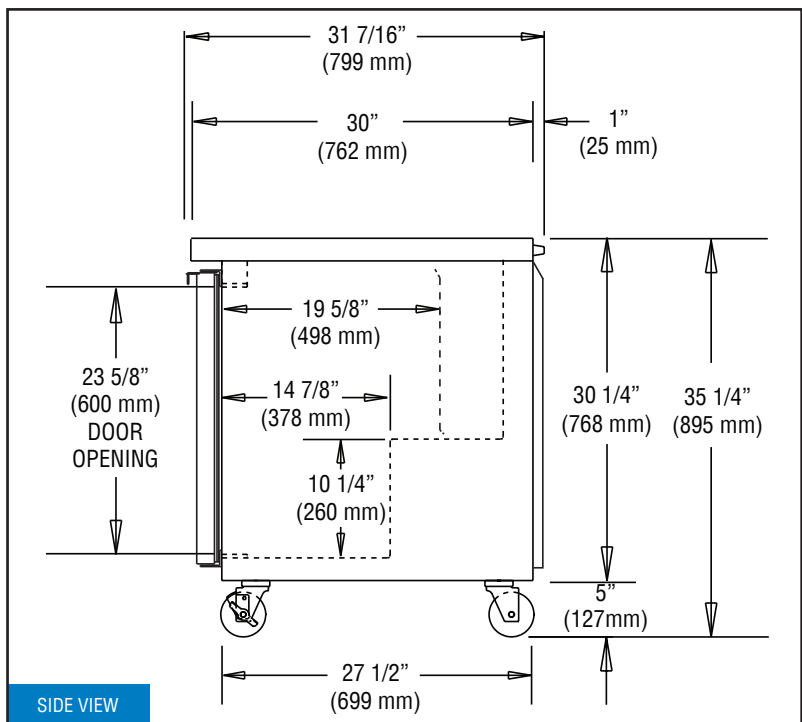

SIDE VIEW

IMPORTANT NOTE: If the cabinet is located directly against a wall, a minimum clearance of 3" is required on sides, front and rear.

Continental
Refrigerator

Toll-Free: 800-523-7138
Phone: 215-244-1400
Fax: 215-244-9579

539 Dunksferry Road
Bensalem, PA 19020
www.continentalrefrigerator.com

Due to our continued efforts in developing innovative products, specifications subject to change without notice.



PROUDLY
DESIGNED & ASSEMBLED
IN THE U.S.A.