

# WORKTOP FREEZER (0°F)

**Model: SWF48N-FB-D**  
 Natural Refrigerant R-290 Model

**48" Worktop Freezer with Drawers  
 Front Breathing**

Stainless steel front, top and end panels, aluminum back and interior.



## Options and Accessories

(upcharge and lead times may apply)

Stainless steel interior	Drawer locks
Stainless steel back	Special electrical requirements (consult factory)
Overshelves (single or double)	

Consult factory for other model configurations, options and accessories.



**Project Name:** \_\_\_\_\_

**Model Specified:** \_\_\_\_\_

**Location:** \_\_\_\_\_

**Item No:** \_\_\_\_\_ **Quantity:** \_\_\_\_\_

**AIA #:** \_\_\_\_\_ **SIS #:** \_\_\_\_\_

## Standard Model Features

- REFRIGERATION SYSTEM**
- Performance rated refrigeration system
  - Natural, environmentally safe, high efficiency R-290 refrigerant<sup>1</sup>
  - Automatic, hot gas condensate evaporator
  - Non-corrosive, plasticized fin evaporator coil
  - Easily serviceable, back mounted compressor

- CABINET ARCHITECTURE**
- 2" non-CFC polyurethane foam insulation
  - Smooth, polished chrome drawer handles
  - Stainless steel roll out drawers
  - Magnetic snap in Santoprene™ drawer gaskets
  - Completely enclosed, vented and removable case back
  - 3 3/4" casters

- MODEL FEATURES**
- Electronic control, automatic electric defrost

<sup>1</sup> R-290 refrigerant meets all federal and state regulatory requirements.

Front breathers are a unique, field assembled, bottom mounted ventilation system designed to allow cabinets to be flush against a wall or built into a counter to conserve space.

**APPROVAL:** \_\_\_\_\_

## Model Specifications

### DIMENSIONAL DATA

Net Capacity (cubic feet)	13.4 (379 cu l)
Width, Overall (inches)	48 (1219 mm)
Depth, Overall (inches) (including handles & bumpers)	32 3/16 (818 mm)
Height, Overall (inches) (including 3 3/4" casters)	34 (864 mm)
Number of Drawers (two tier)	4

### REFRIGERANT DATA

Condensing Unit Size (H.P.)	1/2
Capacity (BTU per hour)*	2078

### ELECTRICAL DATA

Voltage (International)	115/60/1 (220/50/1)
Total Amps (International)	7.7 (4.3)
Defrost Amps (International)	4.4 (2.5)
10 ft. Cord/Plug [attached] (International)	Yes (No)

### SHIPPING DATA

Weight (pounds)	364 (166 kg)
Height - Crated (inches)	42 (1067 mm)
Width - Crated (inches)	56 (1422 mm)
Depth - Crated (inches)	37 1/4 (946 mm)

### DRAWER PAN CONFIGURATIONS

**Two Tier:** (1) 12 x 18 x 6 pan per drawer  
or (1) 1/2 size x 6 & (1) 1/3 x 6 pans per drawer

\* Rating @ -15°F evaporator, 90°F ambient  
Figures in parentheses reflect metric equivalents rounded to the nearest whole unit.



Equipped with one NEMA-5-15P Plug  
(varies by country)

## Model Plan Views

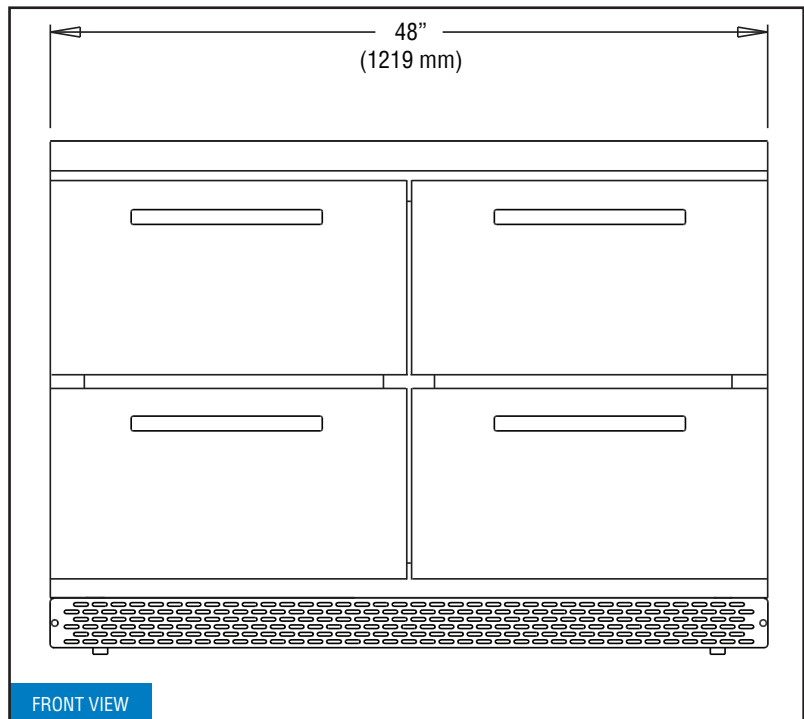

FRONT VIEW

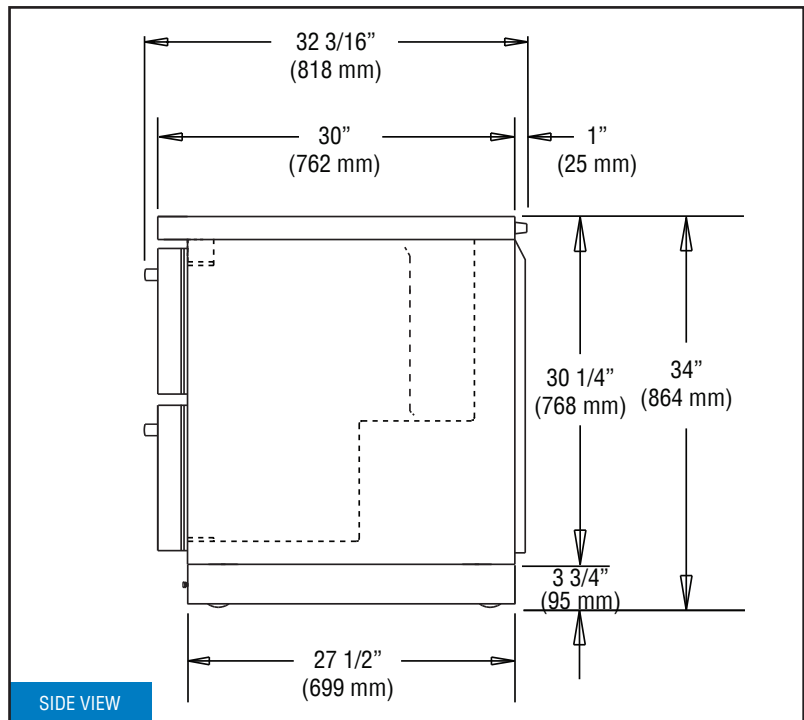

SIDE VIEW

**NOTE:** For proper operation, the area under and in front of the cabinet **must** not be obstructed in any way.

**Continental**  
Refrigerator

Toll-Free: 800-523-7138  
Phone: 215-244-1400  
Fax: 215-244-9579

539 Dunkserry Road  
Bensalem, PA 19020  
[www.continentalrefrigerator.com](http://www.continentalrefrigerator.com)

Due to our continued efforts in developing innovative products, specifications subject to change without notice.



PROUDLY  
DESIGNED & ASSEMBLED  
IN THE U.S.A.

Intertek

© Copyright 2021. Continental Refrigerator.  
A Division of National Refrigeration & Air Conditioning Products, Inc.

REVISED: 4/3/24